



BEVERAGE-AIR

Project: _____	AIA#
Item: _____	
Location: _____	SIS#
Approved: _____	

WTR27HC WORKTOP REFRIGERATOR

SHALLOW DEPTH WORKTOP REFRIGERATOR

WTR27HC Solid Door With Flat Top
Hydrocarbon Series

MODEL:
WTR27HC-FLT



*Note: Shown with optional full electronic control

7 Year Parts/Labor Warranty
7 Year Compressor Warranty

CABINET CONSTRUCTION

- Stainless steel front, sides, door and grille (galvanized back & bottom)
- Interior liner is made of corrosion resistant aluminum
- Stainless steel top for added durability
- Flat top
- Mechanical control
- Interior thermometer is standard
- Self-closing door with 120° stay-open feature, on lift-off hinges
- Magnetic gasket attached to each door for positive seal
- 6" Casters, two (2) with brakes standard
- Two (2) epoxy-coated steel wire shelves
- Field-reversible door (hinge kit not included)

OPTIONS & ACCESSORIES

- Stainless steel back
- Stainless steel interior
- 16 Gauge stainless steel top
- Full electronic control*
- Additional shelves
- Shelf clips
- Glass door option
- Right or left hinged door
- Locks (solid doors only)
- Wire shelf divider
- Cutting board
- 3" Casters
- 6" Legs (stainless steel, black or seismic/flange)
- Low profile casters
- Roller kit
- Remote option** (see note on back on page)

REFRIGERATION SYSTEM

- Uses environmentally friendly, energy efficient R290 refrigerant, and meets all regulatory requirements for CARB, SNAP, DOE & more
- Adaptive defrost
- Epoxy coated evaporator coil
- Refrigerators capable of maintaining product temperature between 36°F and 38°F



Please verify qualifying units by visiting:
www.energystar.gov/cfs

3779 Champion Blvd., Winston-Salem, NC 27105
1-888-845-9800 Fax: 1-336-245-6453
Beverage-Air.com Sales@bevair.com



BEVERAGE-AIR.

Worktop Refrigerator - Shallow Depth Model: WTR27HC-FLT

MODEL	WTR27HC-FLT
EXTERNAL DIMENSIONAL DATA	
Width Overall	27"
Depth Overall with Handle & Bumper	30"
Height Overall with 6" Casters	35 1/2"
Number of Doors	1
Depth with Door Open 90°	53 1/4"
Door Opening	22 5/8" x 21 5/8"
INTERNAL DIMENSIONAL DATA	
NET Capacity (cubic ft.)	5.25
Internal Width Overall (in)	23"
Internal Depth Overall (in)	18"
Internal Height Overall (in)	23"
Number of Shelves	2
ELECTRICAL DATA	
Full Load Amperes	2.0
Voltage	115/60/1
Nema Plug (8' cord)	5-15P
REFRIGERATION DATA	
Horsepower	1/6
Capacity (BTU/Hr)	1110
Heat Rejection (BTU/Hr)	1665
Charge (lbs/grams/ounces)	0.1323 / 60 / 2.12
SHIPPING DATA	
Gross Weight - Crated	161 lbs
Height - Crated	35"
Width - Crated	23"
Depth - Crated	26"

**NOTE: Remote units are field wired and come with 6" legs.
Refrigerant must be specified at time of order.

We reserve the right to change specifications and product design without notice. Such revisions do not entitle the buyer to corresponding changes, improvements, additions or replacements for previously purchased equipment. Dimensional tolerances +/- 1/4". Metric dimensions (MM).

Model Views

Required Clearance: 3" Bottom & 2" Rear

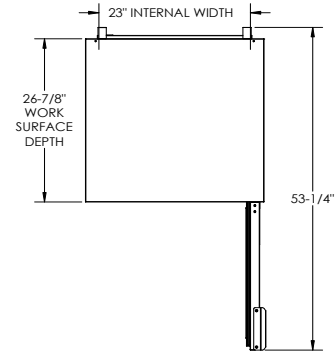

PLAN VIEW

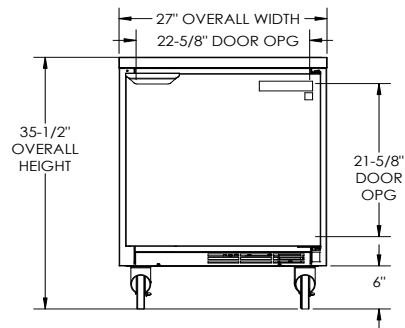

ELEVATION VIEW

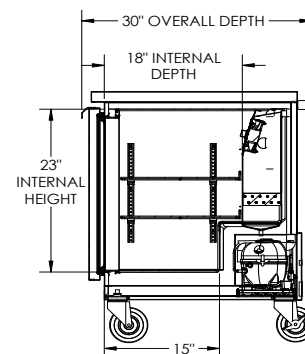

SIDE VIEW

ELECTRICAL CONNECTION



115/60/1
NEMA 5-15P

Unit pre-wired at factory
and include 8' long cord
and plug set.

