



Waterloo 1.15 GPM Pre-Rinse Spray Valve

#750PRSV

Item #: 750PRSV Qty: _____

Project: _____

Approval: _____ Date: _____



Features

- 1.15 GPM flow rate
- Heavy-duty construction
- Fits all Waterloo pre-rinse units
- Ergonomic squeeze handle with hold-down ring
- 3/4" male inlet

Certifications

 3/4" Water Connection
  CSA, US and Canada
  NSF Listed

Technical Data

Features	ASME A112.18.1-2018 / CSA B125.1-18 California AB100 Compliant NSF Listed NSF/ANSI 372 NSF/ANSI 61
Flow Rate	1.15 GPM
Type	Spray Valves
Water Inlet Size	3/4 Inches

Plan View

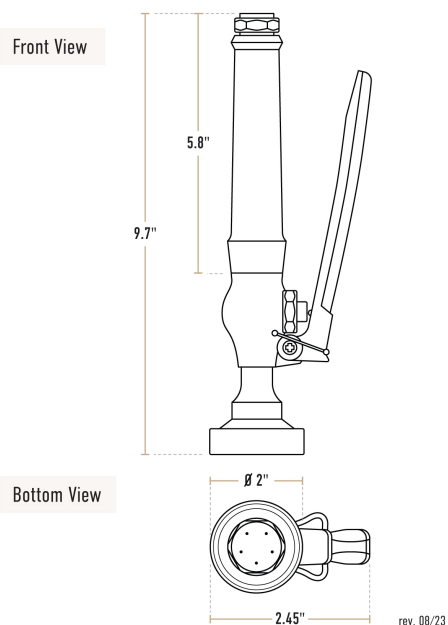

Notes & Details

This Waterloo 1.15 GPM pre-rinse spray valve is an excellent choice when you need to replace a broken valve or upgrade an old one! Designed to provide the industry-leading quality you expect, this spray valve has a heavy-duty body with metal construction to prevent leaks and keep up with even fast-paced dishrooms. It boasts a 1.15 GPM flow rate to blast away heavy soil deposits and ensure that glassware and dinnerware come out of the dishwasher clean and ready to use. It comes with a hold-down ring so that you can lock the valve into the on position for constant use, and its universal design with 3/4" male inlet also allows it to be used on all Waterloo pre-rinse units.

⚠ WARNING: This product can expose you to chemicals including lead, which are known to the State of California to cause cancer, birth defects, or other reproductive harm. For more information, go to www.p65warnings.ca.gov.