



## Waterloo 1.15 GPM Deck-Mounted Pre-Rinse Faucet with Single Base and 10" Add-On Faucet

#750PRD10

Item #: 750PRD10 Qty: \_\_\_\_\_  
 Project: \_\_\_\_\_  
 Approval: \_\_\_\_\_ Date: \_\_\_\_\_



### Features

- 44" hose, 1.15 GPM spray valve
- Deck-mounted design with single base, 1/2" NPT inlets, 20" water lines included
- 1/4 turn ceramic cartridges for long life and leak-protection, check valves prevent backflow
- Heavy-duty faucet base and spray valve, chrome-plated brass construction
- 10" add-on faucet (2 GPM), 18" riser

### Certifications

 CSA, US and Canada
  NSF Listed
  1/2" Water Connection

### Technical Data

|                  |  |
|------------------|--|
| Hose Length      | 44 Inches  |
| Add-On Faucet    | 10 Inches  |
| Add-on Flow Rate | 2 GPM  |
| Cartridge Type   | Ceramic  |
| Faucet Centers   | Single   |
| Features         | ASME A112.18.1-2018 / CSA B125.1-18<br>California AB100 Compliant<br>NSF/ANSI 372<br>NSF/ANSI 61 |
| Handle Type      | Lever  |

## Technical Data

|                       |                        |
|-----------------------|------------------------|
| Material              | Brass                  |
| Mounting Style        | Deck Mounted           |
| Pre Rinse Unit Type   | Hose and Spring        |
| Spout Type            | Swing                  |
| Spray Valve Flow Rate | 1.15 GPM               |
| Temperature Rating    | 180 Degrees Fahrenheit |
| Water Inlet Size      | 1/2 Inches             |

# Plan View

750NZL10

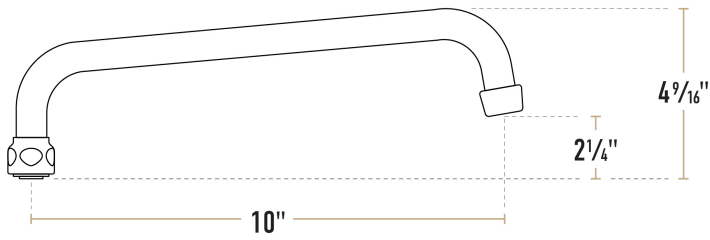

750AFX

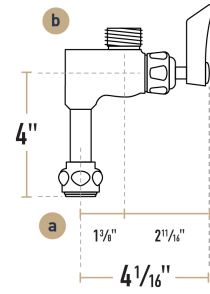

### Connections

- a 1/2" NPT Inlet
- b 3/8" NPT Female Inlet

750PRDX

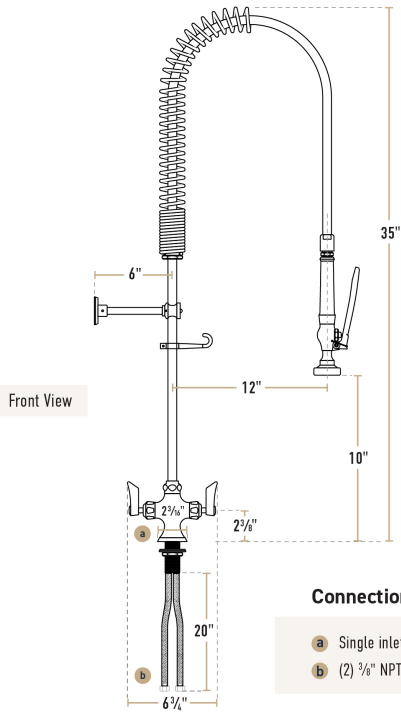

### Connections

- a Single inlet base
- b (2) 3/8" NPT inlets on 20" flexible hoses

750PRRADAPT

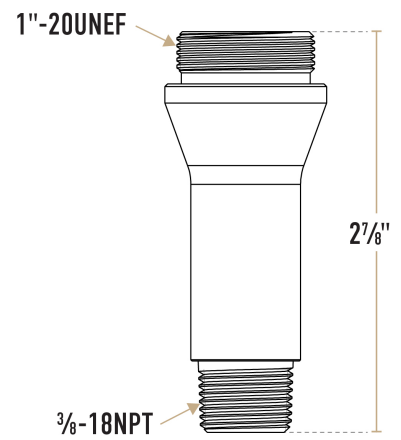

# Notes & Details

---

This Waterloo deck-mounted pre-rinse faucet is perfect for rinsing excess food and sauces off of your dishes prior to running them through your commercial dish machine. A quality pre-rinse unit is vital to any dishroom, removing the heaviest soil deposits so that dishes come out clean and ready to use. Waterloo products provide the industry-leading quality you expect. With heavy chrome-plated brass faucet bodies, ceramic cartridges engineered for durability, and certifications from a wide range of national and local regulatory agencies, you can install Waterloo products with confidence. And to give you total peace of mind, this model comes with a 3-year replacement warranty.

A 44" long flexible hose gives you plenty of reach to deliver water where you need it, letting you handle glassware and dinnerware, or bulky items like pots and pans. The spring has a compressed bottom to provide greater durability and help it retain its shape. The spray valve delivers a flow rate of 1.15 GPM, giving you the power needed to blast away food debris while being easy on your water bill. The heavy-duty valve body is designed with a comfort-grip handle and uses metal components for maximum durability and leak protection. This pre-rinse unit also comes with a 10" add-on faucet, for times when you need a normal faucet instead of a spray valve. It is perfect for filling up sink compartments to complete your warewashing tasks. It's also great for mixing up cleaning solutions in sanitation pails.

This faucet uses ceramic cartridges, which provide a much lower fail rate than the compression cartridges widely used in the industry. In this design, 2 ceramic discs fit together to create a watertight seal when closed. This removes the need for a rubber seat washer, which is one of the most frequently replaced parts on a faucet. This is a deck-mounted faucet, and it comes with a single base that makes installation easy. The 1/2" NPT inlet connections, and a set of 20" flex hoses make it easy to connect it to your facility's water lines. This pre-rinse unit comes with an 18" riser.

 **WARNING:** This product can expose you to chemicals including lead, which are known to the State of California to cause cancer, birth defects, or other reproductive harm. For more information, go to [www.p65warnings.ca.gov](http://www.p65warnings.ca.gov).