

Project	Quantity	Item #
Model Specified:		CSI Section 11400

Roll-In Hot Food Holding Cabinets To Accommodate 72" High Racks



INTELA-TRAUL®
Equipped!



Model RIH132H-FHS



Stainless Exterior
& Interior

One & Two Section Models, 32" Deep

1-Section Roll-In Model
2-Section Roll-In Model

RIH132H-FHS*
RIH232H-FHS



Stainless Exterior,
Anodized Alumi-
num Interior

1-Section Roll-In Model
2-Section Roll-In Model

AIH132H-FHS*
AIH232H-FHS

In addition to the already outstanding cabinet construction you have come to expect from Traulsen, these dependable roll-in hot food holding cabinets are built using our high performance ducted fan air distribution system. Unlike designs which simply radiate heat, this minimizes temperature stratification inside the cabinet, while providing for quicker daily start-up, lower energy usage, and reduced lifetime service costs. Each is supplied standard with easy to operate microprocessor controls, stainless steel exteriors, and are communications capable.

Standard Product Features

- R-Series: Stainless Steel Exterior & Interior
- A-Series: Stainless Steel Exterior/Anodized Aluminum Interior
- INTELA-TRAUL® Patented Microprocessor Control System
- Ducted Fan Air Distribution System
- Standard Operating Temperature Range 135 to 180°F
- One-Time Start-Up Temperature Adjustment Feature
- ON/OFF Switch Located On Control Face
- Full Length Stainless Steel Doors With Locks
- Self-Closing Doors With Stay Open Feature At 120 Degrees
- Guaranteed For Life Cam-Lift Hinges
- Guaranteed For Life Horizontal Work Flow Door Handle(s)
- Standard Door Hinging: 132H = Right, 232H = Left/Right (other hings available)
- Automatically Activated Incandescent Lights
- Stainless Steel Breaker Caps
- Accommodates Roll-In Racks Up To 72" High (provided by others)
- Special Heat Resistant Magnetic Snap-In Door Gaskets
- Stainless Steel Door Liner
- Stainless Steel Interior Rack Guides
- Stainless Steel Threshold Ramp(s)
- Stainless Steel One-Piece Louver Assembly
- 9' Cord & Plug Attached (one section models only)
- One Year Parts And Labor Warranty
- Two Year Control Warranty (parts and labor)

Options & Accessories

- Stainless Steel Finished Back With Rear Louvers
- Re-Hinging Feature For Door(s)
- Wire Shelf Package For Roll-In Models (includes three wire shelves per section)
- Additional Wire Shelves For Above
- Stainless Steel Shelf Package For Roll-In Models (includes three stainless steel shelves per section)
- Additional Stainless Steel Shelves For Above
- Locking Hasps (padlocks supplied by others)
- 115/60/1 Voltage (single section models only)
- Export 220/50/1 Voltage
- Kool Klad Exterior Laminate Decor
- Clear Glass Door(s) In Place Of One Or More Solid Door(s)
- Fluorescent Lights
- Prison/Correctional Facilities Options
- Two Year Service/Labor Warranty Available



* **Noted models are ENERGY STAR® listed. Please refer to www.energystar.gov to view the most up-to-date product listing and performance data.**



Listed by Underwriters Laboratories Inc.,
to U.S. and Canadian safety standards and
Listed by NSF International.

Approval: _____



TRAULSEN
4401 BLUE MOUND RD.
PHONE 1 (800) 825-8220
Website: www.traulsen.com

FT. WORTH, TX 76106
FAX-MKTG. 1 (817) 624-4302
SAP-481 R-A132H-R-A232H

SAP-481
(10/11)

Project	Quantity	Item #
Model Specified:		CSI Section 11400

Specifications

Construction, Hardware and Insulation

Cabinet exterior front, one piece sides, louver assembly and doors are constructed of 20 gauge stainless steel with #4 finish. Cabinet interior and door liners are constructed of stainless steel (anodized aluminum in the A-Series). The exterior cabinet top, back and bottom are constructed of heavy gauge aluminized steel. The interior floor and exterior bottom are constructed of stainless steel and insulated with ¾" of resilient cork. A readily attachable stainless steel ramp is provided.

Doors are equipped with a heavy-duty, extruded wiper gasket for sealing to bottom ramp, removable plug cylinder locks and guaranteed for life cam-lift, gravity action, self-closing metal, glide hinges with stay open feature at 120 degrees. Hinges include a concealed switch to automatically activate the interior incandescent lighting. Guaranteed for life, work flow door handles are mounted horizontally over recess in door which limits protrusion from door face into aiseways. Doors have seamless, polished metal corners.

Easily removable for cleaning, vinyl magnetic door gasket assures tight door seal.

Both the cabinet and door(s) are insulated with an average of 2" thick high density, non-CFC, foamed in place polyurethane.

DIMENSIONAL DATA	R/AIH132H	R/AIH232H
Net capacity cu. ft.	39.0 (1104 cu l)	79.5 (2252 cu l)
Length - overall in.	35½ (90.2 cm)	68 (172.7 cm)
Depth - overall in.	35⅞ (90.3 cm)	35⅞ (90.3 cm)
Depth - over body in.	32 (81.3 cm)	32 (81.3 cm)
Depth - door open 90° in.	63¼ (160.7 cm)	63¼ (160.7 cm)
Clear door width in. ¹	27⅞ (68.8 cm)	27⅞ (68.8 cm)
Clear door height in.	72⅞ (168.4 cm)	72⅞ (168.4 cm)
RIH Net Wt. lbs. ²	480 (218 kg)	785 (356 kg)
AIH Net Wt. lbs. ²	410 (186 kg)	685 (311 kg)
Rack Capacity-72" High	1	2
ELECTRICAL DATA		
Voltage	208/115/60/1	208/115/60/1
Feed wires with Ground	4	4
Wattage @ 208V	1500	3000
Full load amperes @ 208V	7.8	15.5
SHIPPING DATA		
Length - crated in.	41 (104 cm)	73 (160 cm)
Depth - crated in.	44 (112 cm)	44 (112 cm)
Height - crated in.	90½ (230 cm)	90½ (230 cm)
Volume - crated cu. ft.	95 (2691 cu l)	168 (4759 cu l)

NOTES

NOTE: Figures in parentheses reflect metric equivalents.

- 1= Please note that the available cabinet width narrows for 6" from the top of the door frame to 25-7/8" in order to allow for the heater fans.
 2= For shipping weights and dimensions please refer to form TR35875.



Equipped With One NEMA L14-20P Plug
(one section models only)

Heating System

A low watt density, serpentine style, heater is employed for the generation of electric heat. Low velocity air is forced across its large surface area to efficiently move heat radiating away from these through a down-air distribution duct, where it is then evenly distributed throughout the cabinet, assuring the proper holding environment for hot food product, without drying. A vent, located at the top of the cabinet, is included for positive humidity control.

Controller

The easy to use, water resistant INTELA-TRAUL® microprocessor control system is supplied standard. Unit is NAFEM Data Protocol communication (NDP) ready. Optional hardware required to be NDP compliant. Third party software required for network connection. It includes a 3-Digit LED Display, ON/OFF Button, Fahrenheit or Celsius Temperature Scale Display Capability, One-Time Start-Up Temperature Adjustment Feature, and an RS485 data port. In addition it includes audio/visual alarms for: Hi/Lo Cabinet Temperature, Door Open and Power Supply Interruption.

Interior

Readily removable, interior-mounted, stainless steel guides for rack are provided for protection. Maximum rack size with wheels inboard of frame is 27" wide by 29" deep by 66" high. Racks supplied by others.

Warranties

A one year parts and labor warranty is provided standard. An optional 2nd year extended parts and labor warranty is also available. In addition the INTELA-TRAUL® control is warranted by a two year parts and labor warranty.

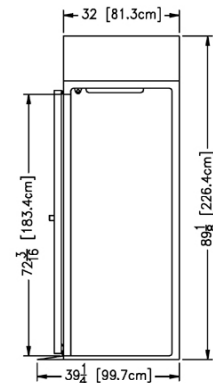
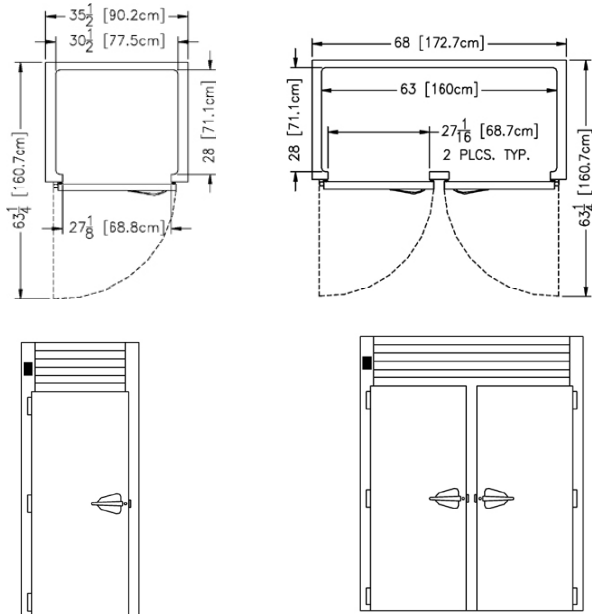

NOTE: When ordering please specify: Voltage, Hinging, Door Size, Options and any additional warranties.

Continued product development may necessitate specification changes without notice.

SAP-481
(10/11)

TRAULSEN
4401 BLUE MOUND RD.
PHONE 1 (800) 825-8220
Website: www.traulsen.com

FT. WORTH, TX 76106
FAX-MKTG. 1 (817) 624-4302

Traulsen