

Project	Quantity	Item #
Model Specified:		CSI Section 11400

### -15°F Reach-In Freezer Models/ Self-Contained



Model Shown Two Section

### Two & Three Section Reach-In Models - 32" Deep



2-Section Full Length Door Model	RSL232NUT-FHS
3-Section Full Length Door Model	RSL332NUT-FHS
2-Section Half Length Door Model	RSL232NUT-HHS
3-Section Half Length Door Model	RSL332NUT-HHS

For those applications, such as ice cream storage, which require even colder operating temperatures, Traulsen offers a line of two and three section reach-in freezer models which operate in the -15° range. They are supplied standard with all of Traulsen's top of the line R-Series features, such as microprocessor controls, stainless steel exterior/interior construction, factory installed interior arrangements, and self-closing doors with a convenient stay open feature. Please note however that actual ice cream storage and consistency characteristics vary due to the wide variety of ice cream products on the market. Selection of any freezer for these applications should be based upon the actual operating temperature required, or determined during previous experience with the specific product to be stored within.

### Standard Product Features

- Traulsen's Smart Control With LED Display
- Stainless Steel Exterior & Interior
- Balanced, Self-Contained Refrigeration System Using R-404A Refrigerant
- Full or Half Length Stainless Steel Doors With Locks
- Self-Closing Doors With Stay Open Feature At 120°
- Guaranteed For Life Cam-Lift Hinges
- Guaranteed For Life Horizontal Work Flow Door Handle
- Standard Door Hinging: 232N = Left/Right, 332N = Left/Right/Right (other hingsings available)
- Automatically Activated LED Lights
- Stainless Steel Breaker Caps
- Three Wire Shelves Per Section, Supported On Shelf Pins (installed at the factory)
- Automatic Bottom Mounted Electric Condensate Evaporator
- Magnetic Snap-In EZ-Clean Door Gasket(s)
- Gasket-Protecting Metal Door Liner
- Thermostatic Expansion Valve Metering Device
- Stainless Steel One-Piece Louver Assembly
- 9' Cord & Plug Attached (two section models only)
- Set of Four (4) 6" High Adjustable Stainless Steel Legs
- Three Year Parts And Labor Warranty
- Five Year Compressor Warranty

### Options & Accessories

- Stainless Steel Finished Back With Rear Louvers
- Re-Hinging Feature For Door(s)
- No. 1 Type Tray Slides To Accommodate either (1) 18" x 26" or (2) 14" x 18" Sheet Pans, Adjustable To 2" O.C.
- No. 4 Type Tray Slides To Accommodate (1) 18" x 26" Sheet Pans (rod type, equips 1/2 section)
- Universal Type Tray Slides To Accommodate Either (1) 18" x 26" or (2) 14" x 18" Sheet Pans, or (2) 12" x 20" Steam Table Pans, Adjustable To 4" O.C.
- Additional Wire Shelves
- Stainless Steel Shelves
- EZ-Change Interiors (#1, universals, universal heavy duty tray slides and shelves)
- EZ-Open Foot Pedal (full height doors only)
- Locking Hasps (padlocks supplied by others)
- Kool Klad Exterior Laminate Decor
- Set of Four (4) 6" High Casters In Lieu of Legs
- Set of Four (4) 4-5/8" High Casters In Lieu of Legs
- 4-1/2" High Stainless Steel Base In Lieu of Legs
- 6" High Stainless Steel Kickplate (for use with standard legs)
- Prison/Correctional Facilities Options
- Remote Applications (see spec sheet TR35837 for more details)



Listed by Underwriters Laboratories Inc., to U.S. and Canadian safety standards and Listed by NSF International.



Approval: \_\_\_\_\_



**TRAUlsen**  
4401 BLUE MOUND RD.  
PHONE 1 (800) 825-8220  
Website: www.traulsen.com

FT. WORTH, TX 76106  
FAX-MKTG. 1 (817) 624-4302

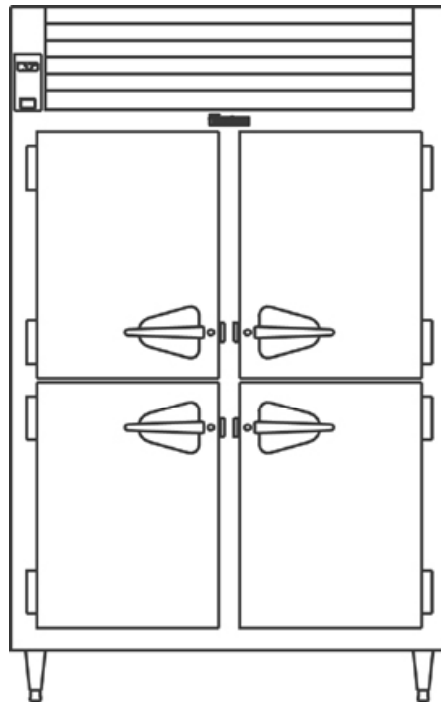

RSL232NUT Front View

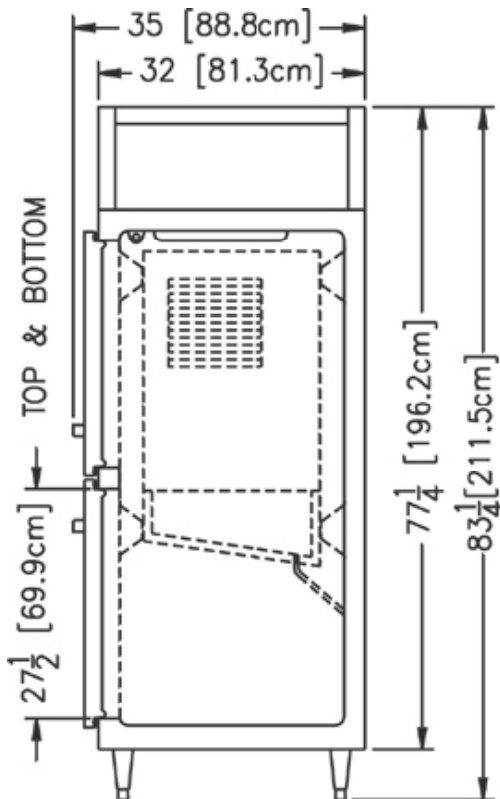

RSL232NUT Side View

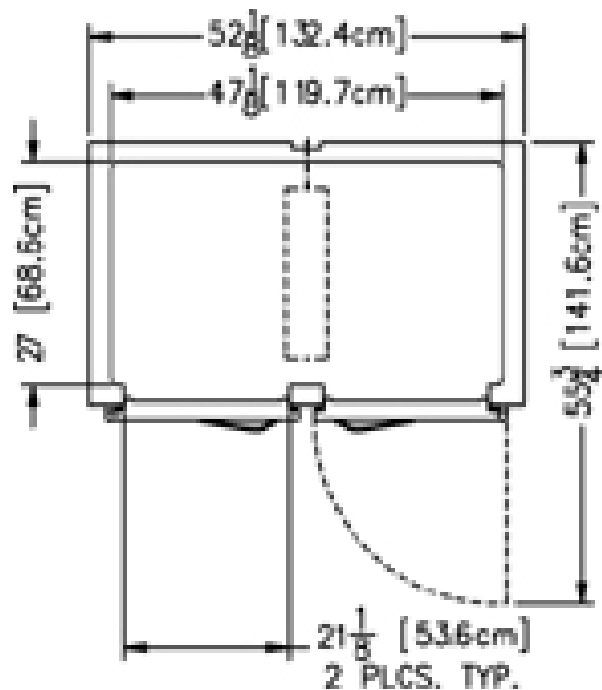

RSL232NUT Top View

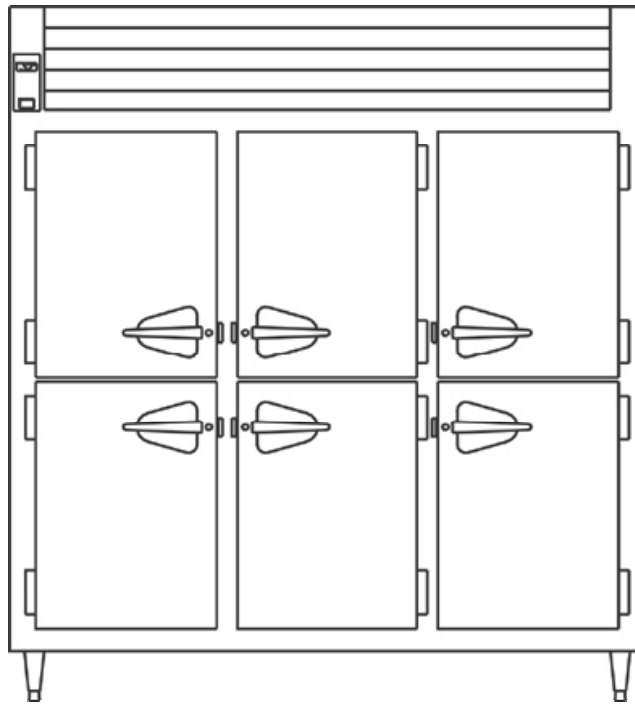

RSL332NUT Front View

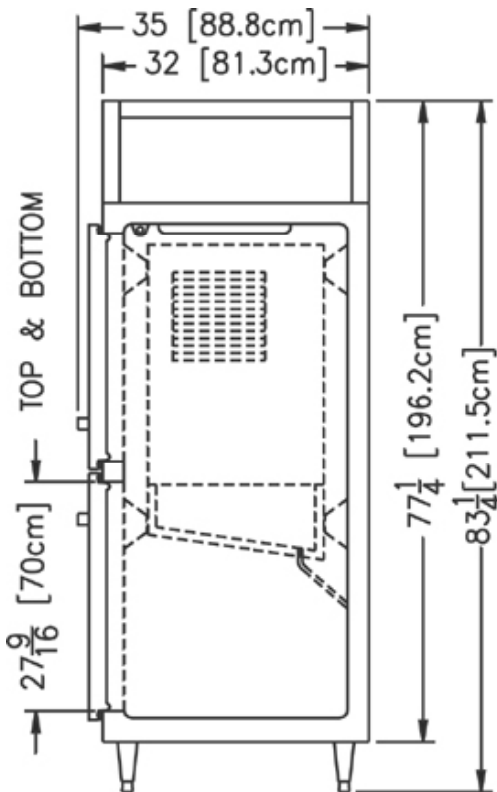

RSL332NUT Side View

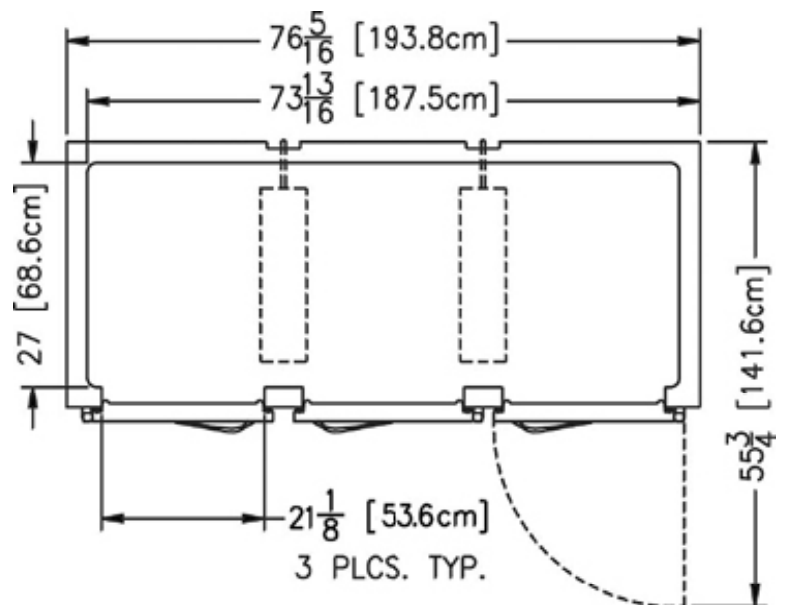

RSL332NUT Top View



TRAUlsen  
 4401 BLUE MOUND RD.  
 PHONE 1 (800) 825-8220  
 Website: www.traulsen.com

FT. WORTH, TX 76106  
 FAX-MKTG. 1 (817) 624-4302

Project	Quantity	Item #
Model Specified:		CSI Section 11400

## Specifications

### Construction, Hardware and Insulation

Cabinet exterior front, one piece sides, louver assembly and doors are constructed of 20 gauge stainless steel with #4 finish. Cabinet interior and door liners are constructed of stainless steel. The exterior cabinet top, back and bottom are constructed of heavy gauge galvanized steel. A set of four (4) adjustable 6" high stainless steel legs are included.

Doors are equipped with a gasket protecting metal door pan, removable plug cylinder locks and guaranteed for life cam-lift, gravity action, self-closing metal, glide hinges with stay open feature at 120°. Hinges include a concealed switch to automatically activate the interior incandescent lighting. Guaranteed for life, work flow door handles are mounted horizontally over recess in door which limits protrusion from door face into aiseways. Doors have seamless, polished metal corners.

Gasket profile and Santoprene® material simplify cleaning and increase overall gasket life. Anti-condensate heaters are located behind each door opening.

Both the cabinet and door(s) are insulated with an average of 2" thick high density, non-CFC, foamed in place polyurethane.

### Refrigeration System

The fast-freezer includes an auxiliary fan for increased air circulation and a boost in refrigeration so the cabinet can operate in the -10 to -20° F range. Increased refrigeration is accomplished by the use of a 1 HP in lieu of a 3/4 HP compressor on a two section narrow model. On a 3-section narrow door model, we supply (2) 3/4 HP compressors in lieu of a (1) 1 HP compressor.

These freezer models contain mullion coolers with an auxiliary fan for increased air flow throughout the interior of the cabinet. This affords maximum heat transfer between the air and product, resulting in faster freezing.

### Controller

Traulsen's Smart Control features advanced control algorithms and sophisticated diagnostic capabilities. Smart sensors will adapt the operation of the system to a variety of environments and usage patterns. The Smart Control offers a complete set of visual alarms designed to alert the user to critical events. In the event of an alarm, a dedicated Alarm LED will illuminate, informing the user of the critical event and describing the event in the large, easy to read full text display

### Interior

Standard interior arrangements include three (3) coated wire shelves per section, mounted on shelf pins. Shelves are full-width, and do not have any large gaps between them requiring the use of "bridge" or "junior shelves". Recommended load limit per shelf should not exceed 225 lbs. Optional tray slides may be purchased in combination with, or in lieu of these. Interior arrangements are installed at the factory and EZ-Change interior slides (only) are field installed.

### Warranties

Both a three year parts and labor warranty and a five year compressor warranty (self-contained models only) are provided standard.

DIMENSIONAL DATA	RSL232NUT	RSL332NUT
Net capacity cu. ft.	46.0 (1303 cu l)	69.5 (1969 cu l)
Length - overall in.	52 $\frac{1}{8}$ (132.4 cm)	76 $\frac{5}{16}$ (193.8 cm)
Depth - overall in.	35 (88.8 cm)	35 (88.8 cm)
Depth - over body in.	32 (81.3 cm)	32 (81.3 cm)
Depth - with door open 90°s in.	55 $\frac{3}{4}$ (141.6 cm)	55 $\frac{3}{4}$ (141.6 cm)
Clear door width in.	21 $\frac{1}{8}$ (53.6 cm)	21 $\frac{1}{8}$ (53.6 cm)
Clear half-door height in.	27 $\frac{1}{2}$ (69.9 cm)	27 $\frac{1}{2}$ (69.9 cm)
Clear full-door height in.	57 $\frac{5}{8}$ (146.3 cm)	57 $\frac{5}{8}$ (146.3 cm)
Height - overall on 6" legs <sup>3</sup>	83 $\frac{3}{4}$ (211.5 cm)	83 $\frac{3}{4}$ (211.5 cm)
Shelf area sq. ft.	34.6 (3.21 cm)	51.9 (4.82 cm)
Net Wt. lbs. <sup>2</sup>	700 (318 kg)	995 (451 kg)
ELECTRICAL DATA		
Voltage	208-230/115/60/1	208-230/115/60/1
Feed wires with Ground	4	4
Full load amperes	10.2	18.4
REFRIGERATION DATA		
Refrigerant	R-404A	R-404A
BTU/HR H.P. <sup>1</sup>	4130 (1 HP)	2 x 5560 ( $\frac{3}{4}$ HP)

### NOTES

NOTE: Figures in parentheses reflect metric equivalents.

1=Based on a 90°F ambient and -20° F evaporator.

2=For approximate remote weights deduct 40 lbs. from respective net or gross weight. For other information on remote models, please refer to spec sheet TR35875.

3=12" Top clearance preferred for optimum performance and service access.



**Equipped With One NEMA L14-20P Plug  
(two section model only)**

Full load amps and plug style may vary depending on electrical options chosen and condensing unit employed.

**NOTE: When ordering please specify: Voltage, Hinging, Door Size, Options and any additional warranties.**

Continued product development may necessitate specification changes without notice.

Part No. TR35807 (REV. 01-15-19)

**TRAULSEN**  
4401 BLUE MOUND RD.  
PHONE 1 (800) 825-8220  
Website: [www.traulsen.com](http://www.traulsen.com)

FT. WORTH, TX 76106  
FAX-MKTG. 1 (817) 624-4302

