

REFRIGERATOR MANUFACTURER
Turbo air
 more durable, efficient, beautiful

4184 E. Conant St.
 Long Beach, CA 90808
 Tel. 310-900-1000
 Fax. 310-900-1077
www.turboairinc.com

Project :	
Model # :	
Item # :	Qty :
Available W/H :	
Approval :	

Horizontal Open Display Cases

Slim Line
 Glass Side Panel / Solid Side Panel

Patented Self-Cleaning Condenser



This product is equipped with a fine mesh filter to the front of the condenser to catch dust, and a rotating brush that moves up and down daily to remove excess buildup outward and away.

Model : TOM-50S(B) / TOM-50S-SP(-A)
NO PLUMBING REQUIRED



TOMD-H

Top display dry case available (optional)



TOM-50SB



TOM-50SB-SP-A

Solid side panel available* (optional, SB only)

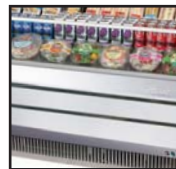

TOM-S-SF

Stainless steel front panel available (optional)*



TOM-50S

FEATURES & BENEFITS

▪ **Maintenance-free, Self-Cleaning Condenser (patented) Only at Turbo Air**

The accumulation of dust in the condenser causes the failure or breakdown of refrigerators. Refrigerators run normally until they reach a certain level of accumulation. At some point, when they are over the limit, their performance drops quickly resulting in damage to, or disposal of the stored products in refrigerators. The self-cleaning condenser device keeps the condenser clean and prevents system failure by automatically brushing daily.

▪ **Hot gas condensate system Only Turbo Air models**

Through Turbo Air's creative innovation, the condensate system surfaces have been specially treated to resist corrosion. This not only increases efficiency without the risk of refrigerant leakage from corrosion, but also prevents the overflow of condensate water.

▪ **Modern design**

▪ **Optional solid side panels (SP & SP-A) available* to ensure durability with two interior standards (SB only)**

SP: Stainless steel interior for sanitary purposes
 SP-A: Black coated interior with mirrored sides for maximized display effects

▪ **Optional stainless steel front panel (SF) available***

▪ **Top display dry cases (TOMD) available (optional)**

▪ **Efficient refrigeration system**

Turbo Air's refrigerators are designed with oversized and balanced environmentally friendly R-134A (CFC Free) refrigeration. These include large evaporators and condensers for faster cooling and balanced temperature throughout the cabinet.

▪ **LED lighting interior**

▪ **Standard back-guard improves airflow**

▪ **300 series stainless steel interior standard including back wall, shelves and deck pans**

▪ **Perforated interior back wall and top for improved air flow**

▪ **Foamed with polyurethane, high-density cell insulation (CFC free)**

▪ **Front air intake and rear air discharge**



Model	CU./FT.	# of Bottom Shelves	HP	AMPS	Crated Weight (lbs.)	L x D x H (inches)
TOM-50S(B) TOM-50SB-SP(-A)	8.98	3	1/2	11	481	503/4 x 345/8 x 411/2

Horizontal Open Display Cases

Slim Line
Glass Side Panel / Solid Side Panel

Model : TOM-50S(B) / TOM-50S-SP(A)

ELECTRICAL DATA	
Voltage	115/60/1
Plug Type	Ⓜ NEMA 5-15P
Full Load Amperes	11
Compressor HP	1/2
Refrigerant	R-134A
DIMENSIONAL DATA	
Net Capacity (cu. ft.)	8.98
Ext. Length Overall (in.)	50 ³ / ₄ (1289mm)
Ext. Depth Overall (in.)	34 ⁵ / ₈ (880mm)
Ext. Height Overall (in.)	41 ¹ / ₂ (1054mm)
Int. Length Overall (in.)	48 ³ / ₈ (1229mm)
Int. Depth Overall (in.)	24 (610mm)
Int. Height Overall (in.)	13 (330mm)
Net Weight (lbs.)	370
Gross Weight (lbs.)	481
# of Bottom Shelves	3
Shelf Size (L x D)(in.)	48 ¹ / ₄ x 11 ¹ / ₄
	48 ¹ / ₄ x 14 ¹ / ₄
	48 ¹ / ₄ x 7

Design and specifications subject to change without notice.
Actual shipping weight may differ due to extra packing materials for product protection.

■ WARRANTY : 2 Year Parts and Labor Warranty Additional 3 Year Warranty on Compressor

- Simple plug-in installation
- Patented self-contained system, no plumbing required
- White and black color come standard
- 4" dia. casters available (optional)
- Night cover available (optional, white / black)
- Recommended operating conditions:

TOM models are designed to operate in an environment where temperature & humidity do not exceed 75°F and 55% respectively. Units should not be installed near HVAC vents, fans or doorways that will disrupt the air curtain and compromise the function of the cabinet. Air curtain models will run most efficiently when completely loaded with product.

■ OPTIONAL ACCESSORIES :

- 4" caster, 1/2" diameter & 13 TPI: G8F6500101 (non-brake), G8F6500201 (w/ brake)
- Top display dry cases: TOMD-50-L (Low), TOMD-50-H (High)
- Night cover: NCT-50-W (White), NCT-50-B (Black)
* Night cover option won't be able to apply on TOM-L/S models if TOMD dry case is already installed on top of the unit.
- Stainless steel front panel available: TOM-S-SF (extra lead time will apply, please call factory for more details to order)

Ver.201701

PLAN VIEW

(unit : inch)

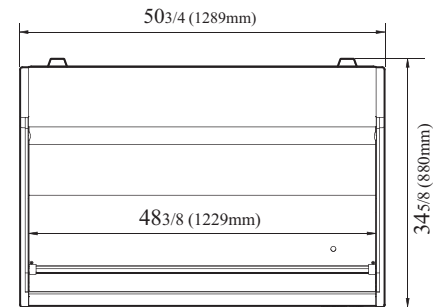

TOP VIEW

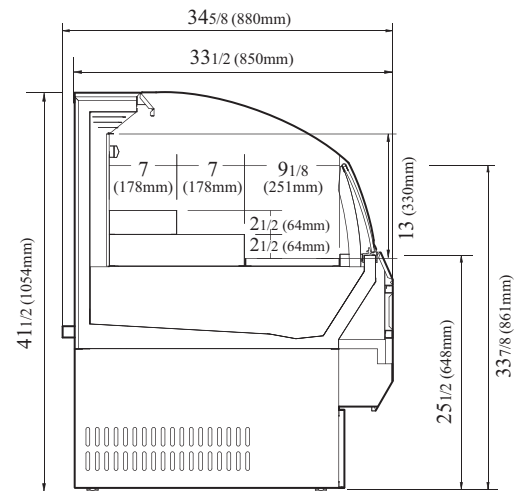

SIDE VIEW

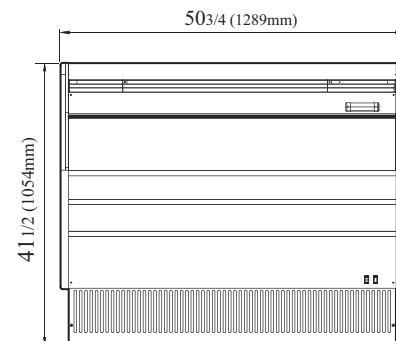

FRONT VIEW



- Turbo Air : 800-627-0032
- GK : 800-500-3519
- Warranty : 800-381-7770
- AC : 888-900-1002

REFRIGERATOR MANUFACTURER
Turbo air

GERMAN KNIFE

RADIANCE

GREEN WORLD

AIR CONDITIONER MANUFACTURER
Turbo air