

StorageBins



TIB-948-A~T-1

A PURPOSE-BUILT ICE BIN – CLEANER BY DESIGN, EASIER TO USE, AND BUILT TO LAST.



Includes True's exclusive **MAGNASCOOP®**



- **Exterior:** TrueTech® clear-coated aluminum with superior corrosion and fingerprint resistance; antimicrobial bin door.
- **Interior:** 100% antimicrobial bin liner.
- **Insulation:** Environmentally friendly, high-density polyurethane foam for maximum ice retention.
- **Design:** Slow-close hinged door and removable ice baffle.
- **Scoop:** Magnetic MagnaScoop® included; stores inside or outside the bin.

Model	Capacity (lbs)	Dimensions (W x D x H*)	Cubic Volume (ft ³)	Crated Weight (lbs)
TIB-948-A~T-1	865	48" x 35" x 50" (1219 x 890 x 1270 mm)	29	230
Bin Drain: 3/4" Female NPT				

*Total height includes 6" legs.

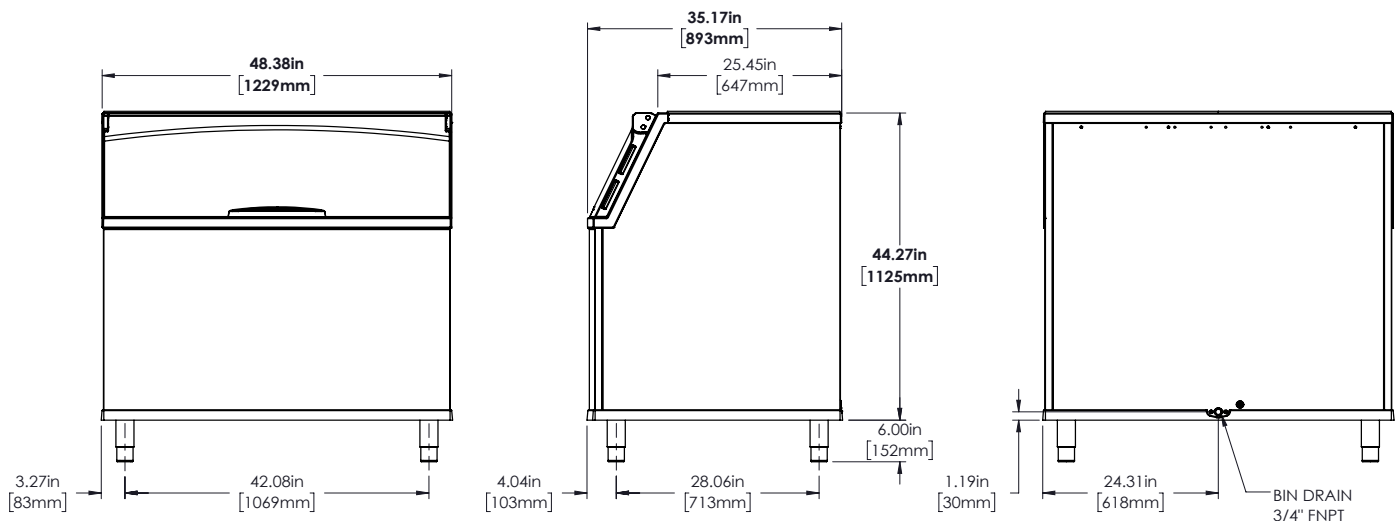

Storage Bin | TIB-948-A~T-1



BIN ADAPTERS

4" Bin Top Adapter (Part #228243)

- Designed for use when installing (2) two 22" machines on a 48" bin.

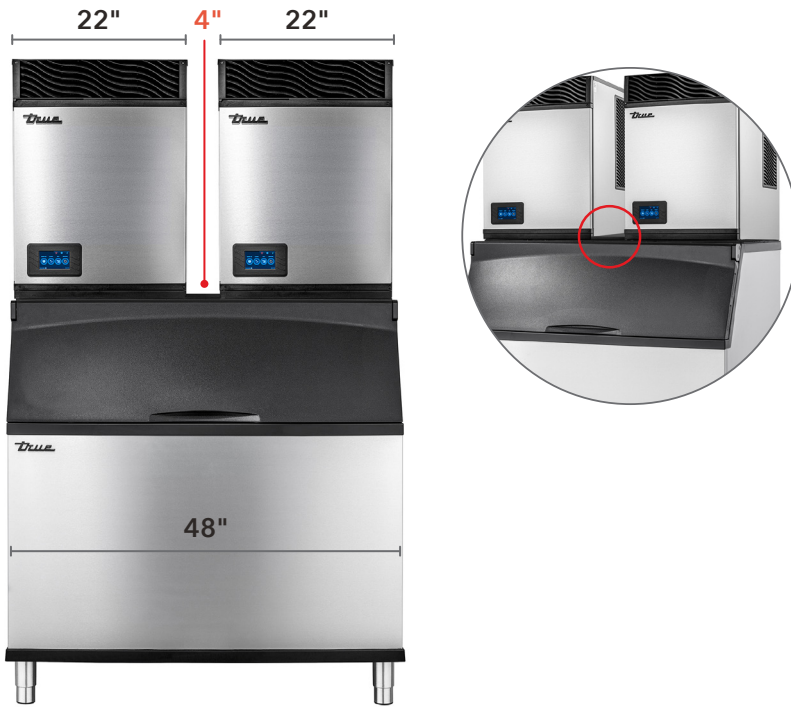

18" Bin Top Adapter (Part #228244)

- Designed for use when installing a 30" machine on a 48" bin.

