

Project name:	Date:
Location:	AIA #:
Manufacturer representative:	Item # / Quantity:

DRYAGER™ UX 750 PRO S

For up to 44 lbs of product*



Professional refrigerated single section dry aging cabinet for commercial production of **dry-aged meats, charcuterie, fish** as well as for the production and storage of cheese and wine in foodservice, hospitality, retail and food processing industries. Equipped with SmartAging™ Technology for easy selection of product-specific dry-aging and curing programs. **Self-contained R600a refrigeration** (115V – 2A) maintains perfect microclimate with electronic temperature (32–86 °F) and humidity (40–90%) control for minimal product loss **without the requirement for water connection or drain**. Unique UX Airreg™ **UV sterilization system** maintains internal air quality and flow without UV exposure of the product. Stainless steel, black or custom colors exterior and antibacterial polystyrene interior with integral rack slides and stainless steel back cover. Cabinet designed for **built-in or free-standing application** for single section or multi-unit integration. The standard warranty is six years compressor, three years parts and labor.



Nº1 BRAND WORLDWIDE** Quality from Germany



The Dry Aging Bible: included with every DRYAGER™ PRO S Cabinet



Conformity
 UL 60335-1: 2016
 UL 60335-2-89: 2017
 CAN/CSA-C22.2 No. 60335-1:16
 CAN/CSA-C22.2 No. 60335-2-89:17
 NSF/ANSI 7: 2016



Standard features

Dry aging and curing programs

- **SmartAging™ Technology** – Enables dry aging with the help of product-specific aging programs, including various flavor intensity profiles as referenced in the Dry Aging Bible (included with cabinet)
- Automatic temperature, humidity and airflow settings carried out by the SmartAging™ processor
- Manual operation also possible without utilizing SmartAging™ Technology

Temperature & Humidity

- Humicontrol™ – steady humidity electronically controlled from **40% to 90%** without the requirement for water connection or drain
- Electronically controlled temperature from **32°F to 86°F**
- Superior aging with minimal weight loss
- Automatic defrost and automatic condensation evaporation

Hygiene

- UVC sterilization system UX Airreg™ – optimal airflow & air quality without UV exposure of the product
- Antibacterial interior with molded slides and coved corners

Visual design

- Stainless steel exterior and door frame
- UX-LED lighting – perfect lighting of displayed products
- Maximum visual appeal & merchandising potential

Safety

- UV protection through tinted double pane glass door
- Visual & audible alarm
- Lockable door and snap-in magnetic gasket

Modularity

- Cabinet designed for free-standing or built-in application for single section or multiple units
- Door hinges reversible

Included accessories: XL accessory package Pro S

- 1 x Book “The Dry Aging Bible” (DU2041) – dry aging knowledge and recipes on more than 300 pages
- 1 x Full shelf (DUS025) & bottom shelf (DUS024) – stainless steel, max. load/shelf 44 lbs
- 1 x SALT AIR tray (DU0075) – stainless steel
- 1 x Hanger (DU0012) – stainless steel, max. load 88 lbs
- 2x Swivel hook – stainless steel, max. load/hook 220 lbs

Standard warranty

- Compressor: 6 years, parts & labor: 3 years

Technical specifications

Internal capacity/net	5.3/4.7 cu. ft. (151/133 liters)
Maximum load	44 lbs (20 kg)
Internal Dimensions HxWxD	28.03 x 19.29 x 17.20 in
External Dimensions HxWxD	35.63 x 23.62 x 24.02 in
Temperature range	32 °F to 86 °F (0 °C to 30 °C)
Humicontrol™	40% to 90%
Connection rating	115 V / 2 A / 60 Hz
NEMA plug configuration	5–15P
Average energy consumption	~1.7 kWh / 24 h
UVC sterilisation system	Yes
SmartAging™ Technology	Yes
Water and drain connection required	No
Automatic defrost and condensation evaporation	Yes

LED interior lighting	Yes
External housing finish	Stainless Steel / Black / Custom Colors
Door material	Stainless Steel / Black / Custom Colors & metallic tinted glass (UV protect)
Door reversible & lockable	Yes
Magnetic door seal, exchangeable	Yes
Door handle	Robust
Alarm	Visual & acoustic
Installation	Integration & free standing
Ambient temperature	50 °F to 95 °F (10 °C to 35 °C)
Refrigerant	R600a
Empty weight	106 lbs
Shipping weight (on pallet)	185 lbs
Shipping dimensions HxWxD (on pallet)	60.00 x 42.00 x 42.00 in

* Maintain at least 2 in clearance between the cabinet walls, door, and food products for proper airflow and performance
 ** For professional dry aging solutions

DRYAGER™ UX 750 PRO S

For up to 44 lbs

Application: Dry Aging of meat



Beef on slide-in shelves



Beef hanging



Half a saddle of pork and beef hanging



Beef on slide-in shelves and pork hanging underneath

SmartAging™ makes it possible: One Cabinet – various applications



Charcuterie production: Sausage and ham*



Dry Aging of fish and seafood*



Dry Aging of meat and poultry*



Production and storing of cheese | tempering champagne and wine*
NEW: Wooden slide-in shelves available

*Shelves in pictures differ from UX 750 PRO S shelves.

DRYAGER™ UX 750 PRO S

For up to 44 lbs

Housing: Color options



All RAL and Pantone colors available

UX 750 PRO S Standard

UX0750PS

Item no.
Housing color

Stainless steel

Door Frame and Handle color

Stainless steel

UX 750 PRO S Black

UX0750PSP

Black, powder-coated

Black, powder-coated

UX 750 PRO S Custom color

UX0750PSC

Custom color premium finish glossy or matte

Custom color premium finish glossy or matte

Custom color solutions available on request: Separate painting of door, housing, handle upon request



DRYAGER™ UX750 PRO S

For up to 44 lbs

Drawings

Front view

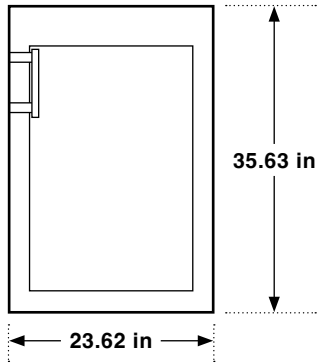

Top view

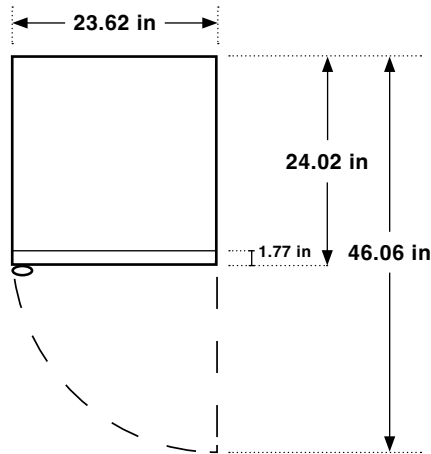

Integration drawing

Single unit installation

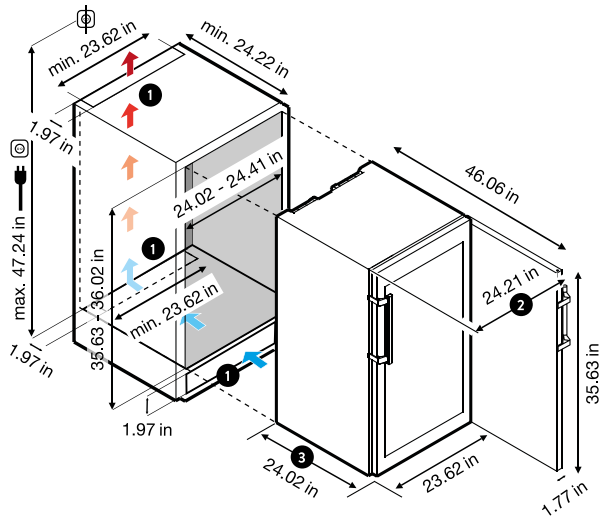

Installation of several devices (on top)

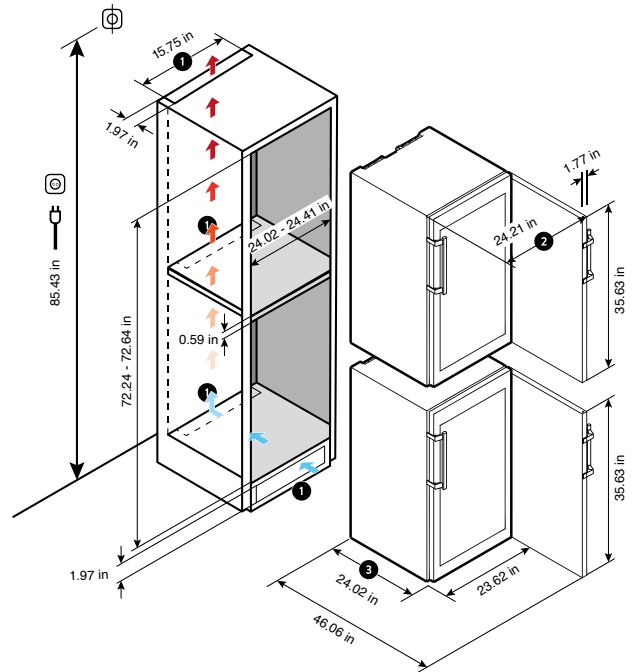

Installation of several devices (side by side)

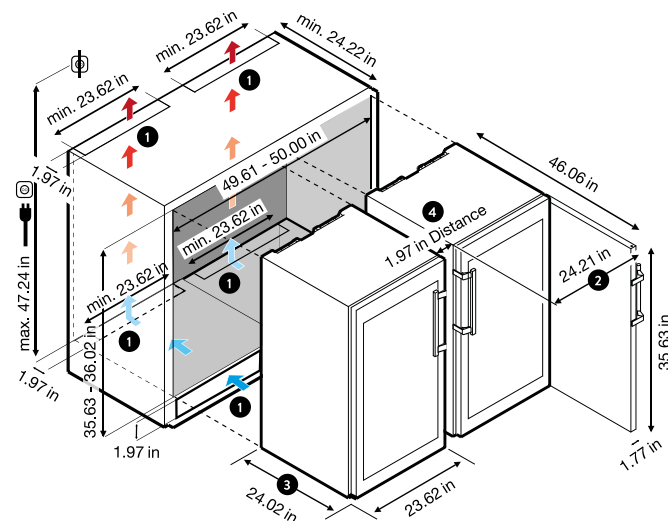

- It is absolutely essential to have good air circulation around the unit. The width of the ventilation shafts needs to be at least the width of the appliance (see ❶). The minimum required depth/height of the shafts is **1.97 in**. Also ensure that the back of the appliance is positioned at a distance of at least **1.97 in** from the wall.
- Overall dimension with opened door (see ❷): **24.21 in**.
- Overall dimension body + door (protruding) (see ❸): **24.02 in**.
- Covering of distance (see ❹) possible by DRYAGER™ moulding, available as an accessory at: shop.dry-ager.com.

DRYAGER™ UX750 PRO S

For up to 44 lbs

Free XL Accessory Package Pro S
Included with every DRYAGER™ PRO S Cabinet



Optional Accessories for UX750 PRO S

Single Accessories

- DU0004 Stainless Steel Moulding**
for side-by-side integration installation of two UX750 PRO units at a distance of 1.97 in.
- DU0012 Hanger**
stainless steel, for hanging up to 2 half saddles of meat, load capacity per hanger: 88lbs, hooks not included
- DUS025 Full Shelf**
stainless steel, for loading over full depth of unit, insertable at many different heights (integral rack slides), load capacity per shelf: 44 lbs
- DUS027 Charcuterie Shelf**
special designed stainless steel shelf for hanging of sausages, salami and ham over half depth of unit, insertable at many different heights (integral rack slides), load capacity per shelf: 22 lbs
- DU0058 SALTAIR Salt-Block Set**
2 pieces of natural crystal salt for optimal support of the humidity regulation, use with DRYAGER™ stainless steel tray (DU0075)
- DU0075 SALTAIR Tray**
high quality stainless steel tray to hold one DRYAGER™ salt-block set (DU0058, not included)
- DU0190 S-Hooks Set**
10 hooks from high quality stainless steel for usage with DRYAGER™ hangers, size 6.3 x 0.3 in, load capacity per hook: 220 lbs
- DU0195 Swivel Hooks Set**
10 swivel hooks from high quality stainless steel, for usage with DRYAGER™ hangers, size 7.1 x 0.3 in, load capacity per hook: 220 lbs

Maintenance

- DU0115 UVC Bulb Replacement Kit**
replacement bulb for annual maintenance of UVC sterilization system
- DUW075 Warranty Extension**
Compressor: 8 years, parts & labor: 4 years

Packages

- DU0130 DRYAGER™ SPECIAL CLEANER Package**
Set of **two** NSF listed cleaners to remove fat, oil, protein residues etc., 16.9 oz (500 ml) spray bottle
- DU0140 XL Meat Label Package**
40 stainless steel skewers with DRYAGER™ designed labels made of reusable plastic
- DU0760 Taste & Operation Package**
1 x SALTAIR salt-block set (DU0058), 1 x XL meat label package (DU0140), 1 x DRYAGER™ SPECIAL CLEANER package (DU0130)
- DU0765 Charcuterie Package**
2x charcuterie shelf (DUS027)
- DU0029 Wooden Shelf Package – beech wood** **NEW**
1 x slide-in self, 1 x bottom shelf made from beech wood, ideal for the presentation of packed food and beverages such as wine
- Package also available in stained beech wood (DU0229)

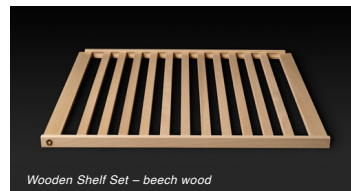

Books

- DU2041 The Dry Aging Bible** **NEW**
The Dry Aging Bible with more than 330 pages is a complete resource offering 89 Dry Aging & cooking recipes, endless inspiration and expert insights.
- Also available in Spanish language (DU2042)

DRYAGER™ UX 750 PRO S

For up to 44 lbs

The Dry Aging Bible – The standard reference on Dry Aging and SmartAging™ included with every DRYAGER™ PRO S Cabinet.

- 336 Pages
- 89 Dry Aging & cooking recipes
- Inspiration & expertise

Our Awards:



Best Book 2022 in the category „Meat & Poultry“



Category E12 Meat Best Book in the world in 2023

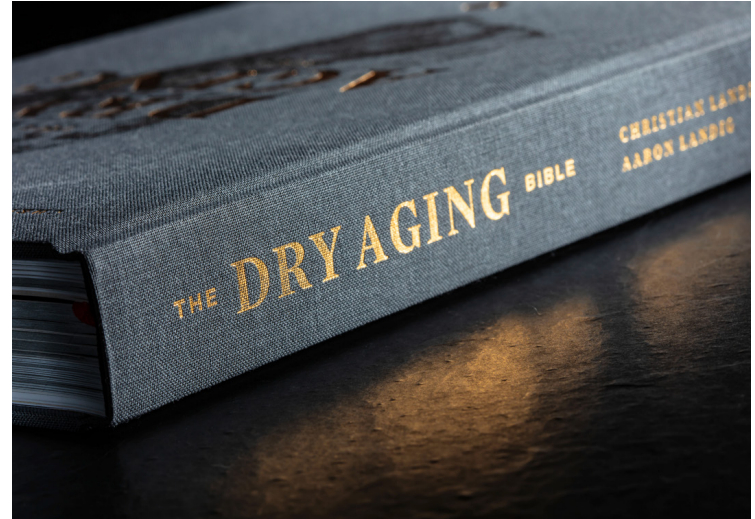

DRY AGER reserves the right to change specifications without notice. This document may be subject to typesetting and printing errors.