

# TC 32 MONTANA

# TC 42 MONTANA

Meat grinders, heavy duty



TC 32 Montana



TC 32 Montana PS



TC 32 Montana PS H

- Powerful – 4 and 7 Hp – floor grinders, designed for large volume meat grinding operations
- Complete stainless steel construction to withstand heavy-duty application and ensure the highest levels of hygiene
- The planetary gear motor provides high-torque and continuous operation yielding up to 7500 lbs./hour
- Fast and easy breakdown and assembly without tools for thorough cleaning
- Supplied with one simple cut knife and plate
- Tray removable on models TC 32 - 42 Montana PS and PS H
- PS: models with electromechanical panel
- H: models with hamburger attachment

## Features

### Technical

- Completely made from AISI 304 stainless steel.
- Square feeding neck allows for faster processing cycles.
- Stainless steel self-sharpening knife and plate.
- Stainless steel knife, stainless steel plate and worm and plate removing tool come standard.
- 5 different plates available (3/16", 1/4", 5/16", 3/8", 9/16").
- Only 2-3 oz. meat remaining in the grinding set at the end of the grinding operation.
- TC 42 Montana the feed opener is 4 3/4" x 5 1/4"

### Safety

- An interlock stops the machine when removing the feed tray.
- A guard is permanently mounted to the sides of the feed tray to protect from accidental contact with the worm.
- A safety interlock stops the machine when removing the grinding set.
- Overcurrent and no-volt release protection

### Sanitary

- The grinding set is quickly disassembled for faster cleaning and sanitation.

## Specifications

- Motor TC 32:** 4 Hp (3000 W), fan cooled.
- Motor TC 42:** 7 Hp (5250 W), fan cooled.
- Electrical:** 220V AC, 60Hz, 3-phase.
- Plug and Cord:** Attached, flexible, 4 wire (3PH+1G) SJT 12 AWG, 6'4" long cord. NEMA 15-20 P
- Controls:** Rotary ON/OFF



Certified to UL Standard 763  
and NSF Standard 08  
Certified to CSA Standard C22.2



TC 42 Montana



TC 42 Montana PS



TC 42 Montana PS H



TC 32 - 42 Montana PS H  
Hamburger attachment

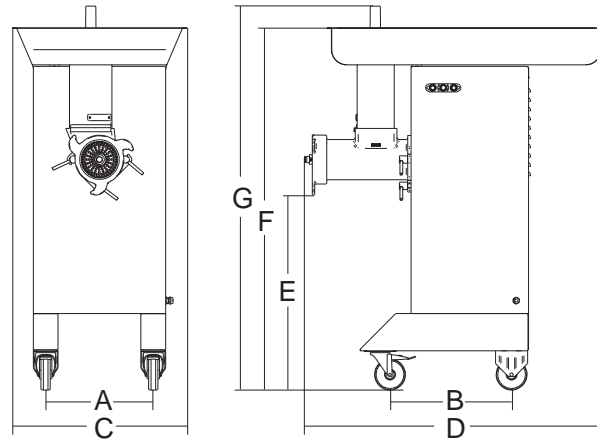

	Power	Power source +/- 10%	Average TC output/h	Standard plate	A	B	C	D	E	F	G	Net weight	Shipping	Gross weight
	watt/Hp		lbs./h.	Ø inch.	inch.	inch.	inch.	inch.	inch.	inch.	inch.	lbs.	inch.	lbs.
<b>TC 32 Montana</b>	3000/4	220V, 60Hz 3-ph	1543	3/16"	13 <sup>45</sup> / <sub>64</sub> "	15 <sup>15</sup> / <sub>32</sub> "	24 <sup>41</sup> / <sub>64</sub> "	44 <sup>19</sup> / <sub>64</sub> "	25"	50 <sup>15</sup> / <sub>32</sub> "	48 <sup>13</sup> / <sub>16</sub> "	200	32" x 48" x 72"	315
<b>TC 32 Montana PS</b>	3000/4	220V, 60Hz 3-ph	1543	3/16"	13 <sup>45</sup> / <sub>64</sub> "	15 <sup>15</sup> / <sub>32</sub> "	24 <sup>41</sup> / <sub>64</sub> "	44 <sup>19</sup> / <sub>64</sub> "	25"	50 <sup>15</sup> / <sub>32</sub> "	48 <sup>13</sup> / <sub>16</sub> "	200	32" x 48" x 72"	315
<b>TC 32 Montana PS H</b>	3000/4	220V, 60Hz 3-ph	1543	3/16"	13 <sup>45</sup> / <sub>64</sub> "	15 <sup>15</sup> / <sub>32</sub> "	24 <sup>41</sup> / <sub>64</sub> "	44 <sup>19</sup> / <sub>64</sub> "	25"	50 <sup>15</sup> / <sub>32</sub> "	48 <sup>13</sup> / <sub>16</sub> "	200	32" x 48" x 72"	315
<b>TC 42 Montana</b>	5250/7	220V, 60Hz 3-ph	2645 - 2866	3/16"	13 <sup>45</sup> / <sub>64</sub> "	15 <sup>15</sup> / <sub>32</sub> "	24 <sup>41</sup> / <sub>64</sub> "	44 <sup>19</sup> / <sub>64</sub> "	25"	50 <sup>15</sup> / <sub>32</sub> "	48 <sup>13</sup> / <sub>16</sub> "	249	32" x 48" x 72"	340
<b>TC 42 Montana PS</b>	5250/7	220V, 60Hz 3-ph	2645 - 2866	3/16"	13 <sup>45</sup> / <sub>64</sub> "	15 <sup>15</sup> / <sub>32</sub> "	24 <sup>41</sup> / <sub>64</sub> "	44 <sup>19</sup> / <sub>64</sub> "	25"	50 <sup>15</sup> / <sub>32</sub> "	48 <sup>13</sup> / <sub>16</sub> "	249	32" x 48" x 72"	340
<b>TC 42 Montana PS H</b>	5250/7	220V, 60Hz 3-ph	2645 - 2866	3/16"	13 <sup>45</sup> / <sub>64</sub> "	15 <sup>15</sup> / <sub>32</sub> "	24 <sup>41</sup> / <sub>64</sub> "	44 <sup>19</sup> / <sub>64</sub> "	25"	50 <sup>15</sup> / <sub>32</sub> "	48 <sup>13</sup> / <sub>16</sub> "	249	32" x 48" x 72"	340