



Profit from the Eagle Advantage®

# Specification Sheet

## Short Form Specifications

Eagle worktables, Spec-Master® series, model \_\_\_\_\_. Top to be constructed of 14/304 stainless steel, with 1½" roll on front, 1½" rear upturn, and sides turned down 90°. Undershef to be adjustable and constructed of 18/304 stainless steel with marine edge. Top reinforced with stainless steel hat channels and sound deadened. Constructed with uni-lok® patented gusset system with the gussets recessed into the hat channels to reduce lateral movement. Legs to be 1½" O.D., stainless steel, with stainless steel gussets and 1" stainless steel adjustable bullet feet.



worktable with upturn and adjustable undershef

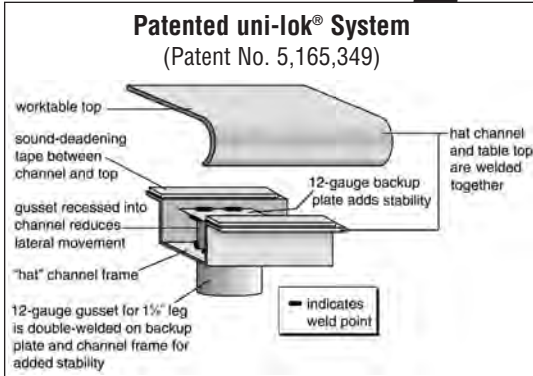

## Options / Accessories

- Drawer
- Lock
- Casters
- Stainless steel bullet feet
- Overshelves
- Duplex receptacles
- Pot rack
- Sink
- Additional undershef
- Stabilizer Bar (for 30"- and 36"-wide tables)

**EAGLE GROUP**  
100 Industrial Boulevard, Clayton, DE 19938-8903 USA  
Phone: 302-653-3000 • Fax: 302-653-2065  
www.eaglegrp.com

**Foodservice Division: Phone 800-441-8440**  
**MHC/Retail Display Divisions: Phone 800-637-5100**

For custom configuration or fabrication needs, contact our **SpecFAB® Division**.  
Phone: 302-653-3000 • Fax: 302-653-3091 • e-mail: specfab@eaglegrp.com

Item No.: \_\_\_\_\_  
Project No.: \_\_\_\_\_  
S.I.S. No.: \_\_\_\_\_

## Worktables with Rear Upturn and Stainless Steel Base with Adjustable Undershef —Spec-Master® Series

### MODELS:

- |                                   |                                    |                                    |                                    |
|-----------------------------------|------------------------------------|------------------------------------|------------------------------------|
| <input type="checkbox"/> UT2424SE | <input type="checkbox"/> UT24108SE | <input type="checkbox"/> UT3072SE  | <input type="checkbox"/> UT3660SE  |
| <input type="checkbox"/> UT2430SE | <input type="checkbox"/> UT24120SE | <input type="checkbox"/> UT3084SE  | <input type="checkbox"/> UT3672SE  |
| <input type="checkbox"/> UT2436SE | <input type="checkbox"/> UT24132SE | <input type="checkbox"/> UT3096SE  | <input type="checkbox"/> UT3684SE  |
| <input type="checkbox"/> UT2448SE | <input type="checkbox"/> UT24144SE | <input type="checkbox"/> UT30108SE | <input type="checkbox"/> UT3696SE  |
| <input type="checkbox"/> UT2460SE | <input type="checkbox"/> UT3030SE  | <input type="checkbox"/> UT30120SE | <input type="checkbox"/> UT36108SE |
| <input type="checkbox"/> UT2472SE | <input type="checkbox"/> UT3036SE  | <input type="checkbox"/> UT30132SE | <input type="checkbox"/> UT36120SE |
| <input type="checkbox"/> UT2484SE | <input type="checkbox"/> UT3048SE  | <input type="checkbox"/> UT30144SE | <input type="checkbox"/> UT36132SE |
| <input type="checkbox"/> UT2496SE | <input type="checkbox"/> UT3060SE  | <input type="checkbox"/> UT3648SE  | <input type="checkbox"/> UT36144SE |

### Tabletop

- Patented uni-lok® gusset system (patent #5,165,349): gussets are recessed into hat channel, reducing lateral movement.
- Top reinforced with welded-on hat channel.
- Sound-deadened between top and channels.
- 1½" (38mm) 90° rear upturn with radius at intersection.
- 1½" (41mm)-diameter 180° rolled edge on front. Ends are turned down 90° providing for flush installations when required.
- 14 gauge type 304 polished stainless steel.

### Adjustable Undershef

- Heavy gauge stainless steel.
- Gusset welded to each corner.
- Heavy duty marine edge.

### Legs—1½" (41mm)-diameter

- Units 96" to 120" (2438 to 3048mm) long come with six legs; Units 132" and 144" (3353 and 3658mm) come with eight legs.
- Heavy gauge stainless steel.
- 1" (25mm) adjustable stainless steel feet.

### Certifications / Approvals



**AUTOQUOTES**



EG10.48C Rev. 11/11

Spec sheets available for viewing, printing or downloading from our online literature library at [www.eaglegrp.com](http://www.eaglegrp.com)

Eagle Foodservice Equipment, Eagle MHC, SpecFAB®, and Retail Display are divisions of Eagle Group. ©2011 by the Eagle Group

Catalog Specification Sheet No. **EG10.48C** Spec-Master® Series Worktables with Rear Upturn and Stainless Steel Base with Undershef



Item No.: \_\_\_\_\_  
 Project No.: \_\_\_\_\_  
 S.I.S. No.: \_\_\_\_\_

## Worktables with Rear Uprturn and Stainless Steel Base with Adjustable Undershelf—Spec-Master® Series

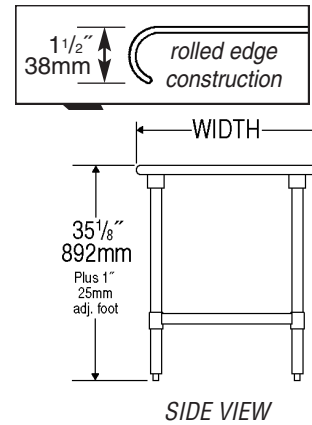
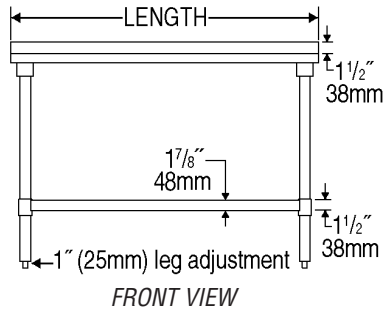
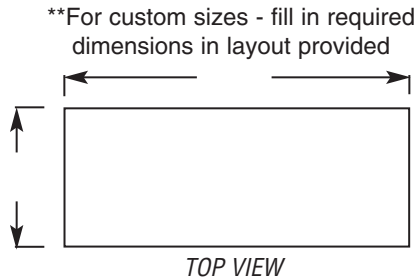

model #	# of legs	width		length		weight	
		in.	mm	in.	mm	lbs.	kg
UT2424SE	4	24"	610	24"	610	44	20.0
UT2430SE	4	24"	610	30"	762	50	22.7
UT2436SE	4	24"	610	36"	914	55	24.9
UT2448SE	4	24"	610	48"	1219	66	29.9
UT2460SE	4	24"	610	60"	1524	77	34.9
UT2472SE	4	24"	610	72"	1829	88	39.9
UT2484SE	4	24"	610	84"	2134	99	44.9
UT2496SE	6	24"	610	96"	2438	110	49.9
UT24108SE	6	24"	610	108"	2743	121	54.9
UT24120SE	6	24"	610	120"	3048	132	59.9
UT24132SE	8	24"	610	132"	3353	143	64.9
UT24144SE	8	24"	610	144"	3658	154	69.9
UT3030SE	4	30"	762	30"	762	55	24.9
UT3036SE	4	30"	762	36"	914	61	27.7
UT3048SE	4	30"	762	48"	1219	72	32.7
UT3060SE	4	30"	762	60"	1524	83	37.6
UT3072SE	4	30"	762	72"	1829	94	42.6
UT3084SE	4	30"	762	84"	2134	105	47.6
UT3096SE	6	30"	762	96"	2438	116	52.6
UT30108SE	6	30"	762	108"	2743	127	57.6
UT30120SE	6	30"	762	120"	3048	138	62.6
UT30132SE	8	30"	762	132"	3353	149	67.6
UT30144SE	8	30"	762	144"	3658	160	72.6
UT3648SE	4	36"	914	48"	1219	83	37.6
UT3660SE	4	36"	914	60"	1524	94	42.6
UT3672SE	4	36"	914	72"	1829	105	47.6
UT3684SE	4	36"	914	84"	2134	116	52.6
UT3696SE	6	36"	914	96"	2438	127	57.6
UT36108SE	6	36"	914	108"	2743	138	62.6
UT36120SE	6	36"	914	120"	3048	149	67.6
UT36132SE	8	36"	914	132"	3353	160	72.6
UT36144SE	8	36"	914	144"	3658	171	77.6

**EAGLE GROUP**  
 100 Industrial Boulevard, Clayton, DE 19938-8903 USA  
 Phone: 302-653-3000 • Fax: 302-653-2065  
 www.eaglegrp.com

Foodservice Division: Phone 800-441-8440  
 MHC/Retail Display Divisions: Phone 800-637-5100

Printed in U.S.A.  
 ©2011 by Eagle Group  
 Rev. 11/11

Spec sheets available for viewing, printing or downloading from our online literature library at [www.eaglegrp.com](http://www.eaglegrp.com)

Although every attempt has been made to ensure the accuracy of the information provided, we cannot be held responsible for typographical or printing errors. Information and specifications are subject to change without notice. Please confirm at time of order.