



Profit from the Eagle Advantage®

Specification Sheet

Short Form Specifications

Eagle worktables, Spec-Master® series, model _____ . Top to be constructed of 14/304 stainless steel with 1½" roll on front, 4½" backsplash, and sides turned down 90°. Open front with 1¼" O.D. galvanized tubular crossbracing on sides and rear. Top reinforced with welded hat channels and sound deadened. Constructed with uni-lok® patented gusset system with the gussets recessed into the hat channels to reduce lateral movement. Legs to be 1½" O.D. galvanized tubing, with galvanized gussets and 1" hi-impact plastic bullet feet.



worktable with backsplash and tubular base —shown with optional drawer

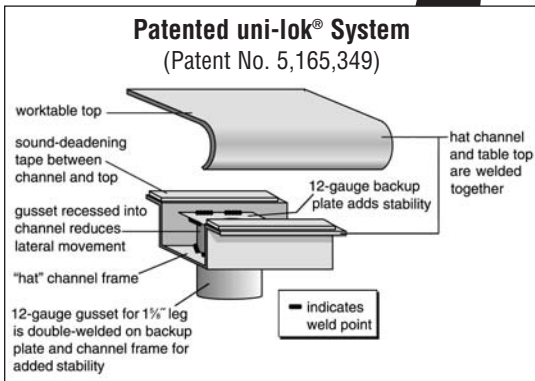

Item No.: _____
 Project No.: _____
 S.I.S. No.: _____

Worktables with Backsplash and Galvanized Tubular Base —Spec-Master® Series

MODELS:

- | | | | |
|--------------------------------------|---------------------------------------|---------------------------------------|---------------------------------------|
| <input type="checkbox"/> T2424GTE-BS | <input type="checkbox"/> T24108GTE-BS | <input type="checkbox"/> T3072GTE-BS | <input type="checkbox"/> T3660GTE-BS |
| <input type="checkbox"/> T2430GTE-BS | <input type="checkbox"/> T24120GTE-BS | <input type="checkbox"/> T3084GTE-BS | <input type="checkbox"/> T3672GTE-BS |
| <input type="checkbox"/> T2436GTE-BS | <input type="checkbox"/> T24132GTE-BS | <input type="checkbox"/> T3096GTE-BS | <input type="checkbox"/> T3684GTE-BS |
| <input type="checkbox"/> T2448GTE-BS | <input type="checkbox"/> T24144GTE-BS | <input type="checkbox"/> T30108GTE-BS | <input type="checkbox"/> T3696GTE-BS |
| <input type="checkbox"/> T2460GTE-BS | <input type="checkbox"/> T3030GTE-BS | <input type="checkbox"/> T30120GTE-BS | <input type="checkbox"/> T36108GTE-BS |
| <input type="checkbox"/> T2472GTE-BS | <input type="checkbox"/> T3036GTE-BS | <input type="checkbox"/> T30132GTE-BS | <input type="checkbox"/> T36120GTE-BS |
| <input type="checkbox"/> T2484GTE-BS | <input type="checkbox"/> T3048GTE-BS | <input type="checkbox"/> T30144GTE-BS | <input type="checkbox"/> T36132GTE-BS |
| <input type="checkbox"/> T2496GTE-BS | <input type="checkbox"/> T3060GTE-BS | <input type="checkbox"/> T3648GTE-BS | <input type="checkbox"/> T36144GTE-BS |

Tabletop

- Patented uni-lok® gusset system (patent #5,165,349): gussets are recessed into hat channel, reducing lateral movement.
- Top reinforced with welded-on hat channel.
- Sound-deadened between top and channels.
- 4½" (114mm)-high 90° backsplash with 1" (25mm) turn at 90°.
- 1½" (38mm)-diameter 180° rolled edge on front. Ends are turned down 90°, providing for flush installations when required.
- 14 gauge type 304 polished stainless steel.

Crossbracing—1¼" (38mm)-diameter

- Heavy gauge, galvanized.
- Aluminum castings join crossbraces, legs and rear brace.

Legs—1½" (41mm)-diameter

- Tables 96" (2438mm) and longer come with six legs or more.
- Heavy gauge galvanized steel.
- 1" (25mm) adjustable hi-impact plastic feet.

Options / Accessories

- | | |
|--|--|
| <input type="checkbox"/> Drawer | <input type="checkbox"/> Duplex receptacles |
| <input type="checkbox"/> Lock | <input type="checkbox"/> Pot rack |
| <input type="checkbox"/> Casters | <input type="checkbox"/> Sink |
| <input type="checkbox"/> Stainless steel bullet feet | <input type="checkbox"/> Stabilizer Bar (for 30"- and 36"-wide tables) |
| <input type="checkbox"/> Overshelves | |

EAGLE GROUP
 100 Industrial Boulevard, Clayton, DE 19938-8903 USA
 Phone: 302-653-3000 • Fax: 302-653-2065
 www.eaglegrp.com

Foodservice Division: Phone 800-441-8440
MHC/Retail Display Divisions: Phone 800-637-5100

For custom configuration or fabrication needs, contact our **SpecFAB® Division**.
 Phone: 302-653-3000 • Fax: 302-653-3091 • e-mail: specfab@eaglegrp.com



EG10.46C Rev. 07/08

Spec sheets available for viewing, printing or downloading from our online literature library at www.eaglegrp.com



Item No.: _____
 Project No.: _____
 S.I.S. No.: _____

Worktables with Backsplash and Galvanized Tubular Base —Spec-Master® Series

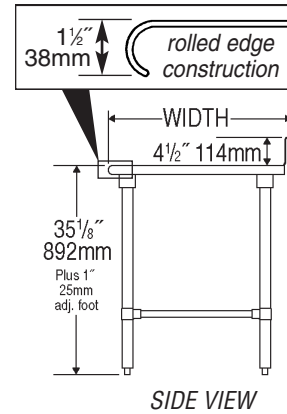
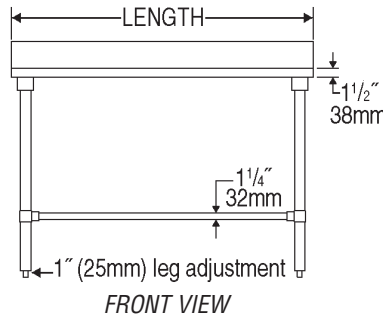
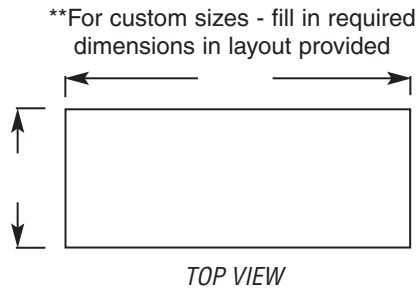

model #	# of legs	width		length		weight	
		in.	mm	in.	mm	lbs.	kg
T2424GTE-BS	4	24"	610	24"	610	45	20.4
T2430GTE-BS	4	24"	610	30"	762	51	23.1
T2436GTE-BS	4	24"	610	36"	914	56	25.4
T2448GTE-BS	4	24"	610	48"	1219	67	30.4
T2460GTE-BS	4	24"	610	60"	1524	78	35.4
T2472GTE-BS	4	24"	610	72"	1829	89	40.4
T2484GTE-BS	4	24"	610	84"	2134	100	45.4
T2496GTE-BS	6	24"	610	96"	2438	110	49.9
T24108GTE-BS	6	24"	610	108"	2743	122	55.3
T24120GTE-BS	6	24"	610	120"	3048	133	60.3
T24132GTE-BS	8	24"	610	132"	3353	144	65.3
T24144GTE-BS	8	24"	610	144"	3658	155	70.3
T3030GTE-BS	4	30"	762	30"	762	56	25.4
T3036GTE-BS	4	30"	762	36"	914	62	28.1
T3048GTE-BS	4	30"	762	48"	1219	73	33.1
T3060GTE-BS	4	30"	762	60"	1524	84	38.1
T3072GTE-BS	4	30"	762	72"	1829	95	43.1
T3084GTE-BS	4	30"	762	84"	2134	106	48.1
T3096GTE-BS	6	30"	762	96"	2438	117	53.1
T30108GTE-BS	6	30"	762	108"	2743	128	58.1
T30120GTE-BS	6	30"	762	120"	3048	139	63.1
T30132GTE-BS	8	30"	762	132"	3353	150	68.0
T30144GTE-BS	8	30"	762	144"	3658	161	73.0
T3648GTE-BS	4	36"	914	48"	1219	78	35.4
T3660GTE-BS	4	36"	914	60"	1524	89	40.4
T3672GTE-BS	4	36"	914	72"	1829	100	45.4
T3684GTE-BS	4	36"	914	84"	2134	111	50.3
T3696GTE-BS	6	36"	914	96"	2438	122	55.3
T36108GTE-BS	6	36"	914	108"	2743	133	60.3
T36120GTE-BS	6	36"	914	120"	3048	144	65.3
T36132GTE-BS	8	36"	914	132"	3353	155	70.3
T36144GTE-BS	8	36"	914	144"	3658	166	75.3

EAGLE GROUP
 100 Industrial Boulevard, Clayton, DE 19938-8903 USA
 Phone: 302-653-3000 • Fax: 302-653-2065
 www.eaglegrp.com

Foodservice Division: Phone 800-441-8440
 MHC/Retail Display Divisions: Phone 800-637-5100

Printed in U.S.A.
 ©2008 by Eagle Group

Rev. 07/08

Spec sheets available for viewing, printing or downloading from our online literature library at www.eaglegrp.com

Although every attempt has been made to ensure the accuracy of the information provided, we cannot be held responsible for typographical or printing errors. Information and specifications are subject to change without notice. Please confirm at time of order.