



Profit from the Eagle Advantage®

Specification Sheet

Short Form Specifications

Eagle worktables, Spec-Master® Marine series, model _____. Top to be constructed of 14/304 stainless steel with 2½" marine counter style edge on all sides. Undershelf to be adjustable and constructed of heavy gauge galvanized. Top reinforced with welded hat channels and sound deadened. Constructed with uni-lok® patented gusset system with the gussets recessed into the hat channels to reduce lateral movement. Legs to be 1½" O.D. galvanized tubing with galvanized gussets and 1" hi-impact plastic bullet feet.



worktable with flat top and undershelf

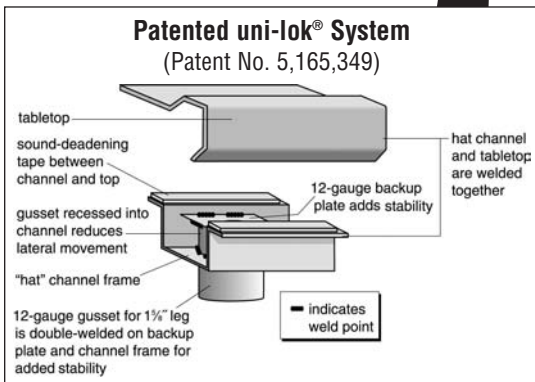

Item No.: _____
 Project No.: _____
 S.I.S. No.: _____

Worktables with Flat Top and Galvanized Base with Adjustable Undershelf —Spec-Master® Marine Series

MODELS:

- | | | | |
|-----------------------------------|-----------------------------------|-----------------------------------|-----------------------------------|
| <input type="checkbox"/> T2424EM | <input type="checkbox"/> T24144EM | <input type="checkbox"/> T30132EM | <input type="checkbox"/> T36144EM |
| <input type="checkbox"/> T2430EM | <input type="checkbox"/> T3030EM | <input type="checkbox"/> T30144EM | <input type="checkbox"/> T4848EM |
| <input type="checkbox"/> T2436EM | <input type="checkbox"/> T3036EM | <input type="checkbox"/> T3648EM | <input type="checkbox"/> T4860EM |
| <input type="checkbox"/> T2448EM | <input type="checkbox"/> T3048EM | <input type="checkbox"/> T3660EM | <input type="checkbox"/> T4872EM |
| <input type="checkbox"/> T2460EM | <input type="checkbox"/> T3060EM | <input type="checkbox"/> T3672EM | <input type="checkbox"/> T4884EM |
| <input type="checkbox"/> T2472EM | <input type="checkbox"/> T3072EM | <input type="checkbox"/> T3684EM | <input type="checkbox"/> T4896EM |
| <input type="checkbox"/> T2484EM | <input type="checkbox"/> T3084EM | <input type="checkbox"/> T3696EM | <input type="checkbox"/> T48108EM |
| <input type="checkbox"/> T2496EM | <input type="checkbox"/> T3096EM | <input type="checkbox"/> T36108EM | <input type="checkbox"/> T48120EM |
| <input type="checkbox"/> T24108EM | <input type="checkbox"/> T30108EM | <input type="checkbox"/> T36120EM | <input type="checkbox"/> T48132EM |
| <input type="checkbox"/> T24120EM | <input type="checkbox"/> T30120EM | <input type="checkbox"/> T36132EM | <input type="checkbox"/> T48144EM |
| <input type="checkbox"/> T24132EM | | | |

Tabletop

- Patented uni-lok® gusset system (patent #5,165,349): gussets are recessed into hat channel, reducing lateral movement.
- Top reinforced with welded-on hat channel.
- Sound-deadened between top and channels.
- Marine counter edge on all four sides.
- 14 gauge type 304 polished stainless steel.

Adjustable Undershelf

- Heavy gauge, galvanized.
- Gusset welded to each corner.

Legs—1½" (41mm)-diameter

- 24" to 36" (610 to 914mm)-wide units that are 96" (2438mm) and longer come with six legs or more. 48" (1219mm)-wide units that are 72" (1829mm) and longer come with six legs or more.
- Heavy gauge galvanized steel.
- 1" (25mm) adjustable hi-impact plastic feet.

Options / Accessories

- | | |
|--|--|
| <input type="checkbox"/> Drawer | <input type="checkbox"/> Duplex receptacles |
| <input type="checkbox"/> Lock | <input type="checkbox"/> Pot rack |
| <input type="checkbox"/> Casters | <input type="checkbox"/> Sink |
| <input type="checkbox"/> Stainless steel bullet feet | <input type="checkbox"/> Additional undershelf |
| <input type="checkbox"/> Overshelves | <input type="checkbox"/> Stabilizer Bar (for 30"- and 36"-wide tables) |



EAGLE GROUP
 100 Industrial Boulevard, Clayton, DE 19938-8903 USA
 Phone: 302-653-3000 • Fax: 302-653-2065
 www.eaglegrp.com

Foodservice Division: Phone 800-441-8440
MHC/Retail Display Divisions: Phone 800-637-5100

For custom configuration or fabrication needs, contact our **SpecFAB® Division**.
 Phone: 302-653-3000 • Fax: 302-653-3091 • e-mail: specfab@eaglegrp.com

EG10.40D Rev. 07/08

Spec sheets available for viewing, printing or downloading from our online literature library at www.eaglegrp.com



Profit from the Eagle Advantage®

Item No.: _____
 Project No.: _____
 S.I.S. No.: _____

Worktables with Flat Top and Galvanized Base with Adjustable Undershelf—Spec-Master® Marine Series

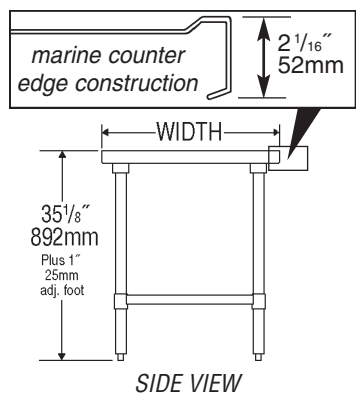
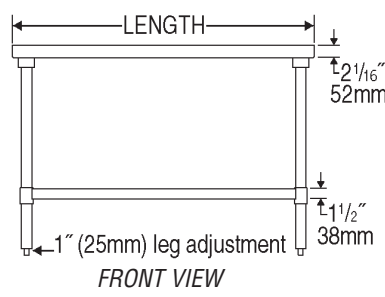
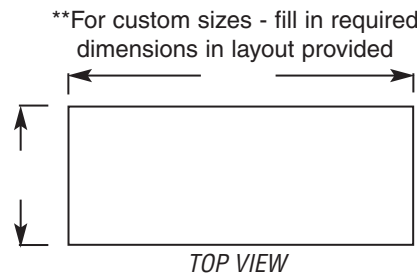

model #	# of legs	width		length		weight	
		in.	mm	in.	mm	lbs.	kg
T2424EM	4	24"	610	24"	610	44	20.0
T2430EM	4	24"	610	30"	762	50	22.7
T2436EM	4	24"	610	36"	914	55	24.9
T2448EM	4	24"	610	48"	1219	67	30.4
T2460EM	4	24"	610	60"	1524	78	35.4
T2472EM	4	24"	610	72"	1829	90	40.8
T2484EM	4	24"	610	84"	2134	103	46.3
T2496EM	6	24"	610	96"	2438	112	50.8
T24108EM	6	24"	610	108"	2743	123	55.8
T24120EM	6	24"	610	120"	3048	134	60.8
T24132EM	8	24"	610	132"	3353	145	65.8
T24144EM	8	24"	610	144"	3658	156	70.8
T3030EM	4	30"	762	30"	762	52	23.6
T3036EM	4	30"	762	36"	914	58	26.3
T3048EM	4	30"	762	48"	1219	71	32.2
T3060EM	4	30"	762	60"	1524	84	38.1
T3072EM	4	30"	762	72"	1829	93	42.2
T3084EM	4	30"	762	84"	2134	107	48.5
T3096EM	6	30"	762	96"	2438	120	54.4
T30108EM	6	30"	762	108"	2743	134	60.8
T30120EM	6	30"	762	120"	3048	147	66.7
T30132EM	8	30"	762	132"	3353	160	72.6
T30144EM	8	30"	762	144"	3658	174	78.9
T3648EM	4	36"	914	48"	1219	78	35.4
T3660EM	4	36"	914	60"	1524	92	41.7
T3672EM	4	36"	914	72"	1829	107	48.5
T3684EM	4	36"	914	84"	2134	120	54.4
T3696EM	6	36"	914	96"	2438	134	60.8
T36108EM	6	36"	914	108"	2743	147	66.7
T36120EM	6	36"	914	120"	3048	160	72.6
T36132EM	8	36"	914	132"	3353	174	78.9
T36144EM	8	36"	914	144"	3658	187	84.8
T4848EM	4	48"	1219	48"	1219	124	54.9
T4860EM	4	48"	1219	60"	1524	146	66.2
T4872EM	6	48"	1219	72"	1829	171	77.6
T4884EM	8	48"	1219	84"	2134	197	89.4
T4896EM	8	48"	1219	96"	2438	241	109.3
T48108EM	8	48"	1219	108"	2743	278	126.1
T48120EM	8	48"	1219	120"	3048	316	143.3
T48132EM	8	48"	1219	132"	3353	353	160.1
T48144EM	8	48"	1219	144"	3658	391	177.4

EAGLE GROUP
 100 Industrial Boulevard, Clayton, DE 19938-8903 USA
 Phone: 302-653-3000 • Fax: 302-653-2065
 www.eaglegrp.com

Foodservice Division: Phone 800-441-8440
 MHC/Retail Display Divisions: Phone 800-637-5100

Printed in U.S.A.
 ©2008 by Eagle Group
 Rev. 07/08

Spec sheets available for viewing, printing or downloading from our online literature library at www.eaglegrp.com

Although every attempt has been made to ensure the accuracy of the information provided, we cannot be held responsible for typographical or printing errors. Information and specifications are subject to change without notice. Please confirm at time of order.