



## Submittal Data

# duraSchwank STW Series

## Outdoor, Car Wash & Harsh Environment Low-Intensity Two-Stage Gas-Fired Infrared Tube Heater

Project

Schwank models #

Fuel

Date submitted

### Features

#### Approvals / Certificates

UL Certification.

ANSI Z83.26 / CSA 2.37 Standard for gas-fired Outdoor Infrared Patio Heaters.

ANSI Z83.20 / CSA 2.34 Standard for Gas-Fired Low-Intensity Infrared Heaters.

#### Burner/Motor

Stainless Steel Water Resistant.

Complete with operation status indicator lights.

Potted direct spark ignition.

Housing: The "Clamshell Design" provides access from the 2 sides, end, and bottom.

#### Power

4' Length 16/3 electrical supply cord with 3 pin grounded plug.

120V/1PH

#### Safety Switch

Two separate air pressure switches sense adequate combustion air and blocked flue.

#### Gas connection

Natural gas: 3.5" W.C. Manifold.

Propane: 10" W.C. Manifold.

Canada: Type 1 hose gas connector is included with each burner kit.

1/2" X 30" 45,000 TO 130,000 AND  
3/4" X 30" 150,000 TO 200,000

USA: Flexible gas connector is included with each burner kit.

1/2" X 24" 45,000 TO 130,000 AND  
3/4" X 24" = 150,000 TO 200,000

#### Reflector

Aluminized steel.

Reflectors are closed at the start and end of each straight run of tubes by end plate hangers.

#### Controls/Thermostat

Factory ready for 24VAC or 120VAC control. On/Off switch control.

Moisture Proof Nema 4X Thermostat.

24V Digital Thermostat. Note: Multiple Heaters Per 24V Thermostat Require Relay Control Center Kit.

ThermoControlPlus.



Read the  
I&O Manual

## Performance

Tag	Qty	Model	Total Heater Length	High-Fire Input (BTU/hr)	Low-Fire Input (BTU/hr)	Turbulator Length	Line Pressure NG/LP	Manifold Pressure NG/LP	Flue & Air Vents	Shipping Weight (lbs.)
		STW2-200-60	60' 4"			72"				282 Lbs
		STW2-200-50	50' 8"	195,000	140,000	40" + 72"	Line minimum:			239 Lbs
		STW2-175-60	60' 4"			40" + 72"				282 Lbs
		STW2-175-50	50' 8"	162,000	115,000	40" + 72"	5" W.C NG 11" W.C LP			239 Lbs
		STW2-155-50	50' 8"			24" (3rd Tube)				239 Lbs
		STW2-155-40	41' 0"	150,000	110,000	24" + 109"		3.5" / 10"	4"	197 Lbs
		STW2-130-40	41' 0"			24" + 109"	Line Maximum:			197 Lbs
		STW2-130-30	31' 4"	120,000	85,000	60" + 96"				154 Lbs
		STW2-110-40	41' 0"			24" + 109"	NG or LP			197 Lbs
		STW2-110-30	31' 4"	110,000	80,000	60" + 96"	14" W.C			154 Lbs
		STW2-80-30	31' 4"			96"				154 Lbs
		STW2-80-20	21' 8"	78,000	58,000	39" + 96"				111 Lbs

For all the heaters above; Gas Inlet is 1/2" NPT. For heaters above 150,000 Btu/hr; Gas Inlet is 3/4 NPT. Electrical is 120V-60Hz, 145 VA.

## Dimensions

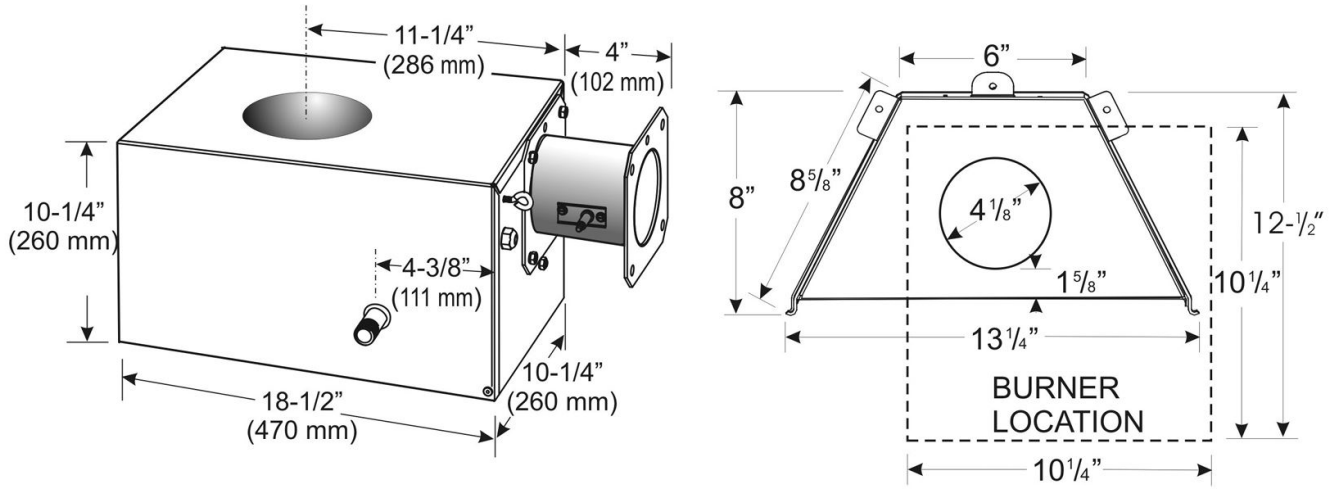

## Side-view of systems:

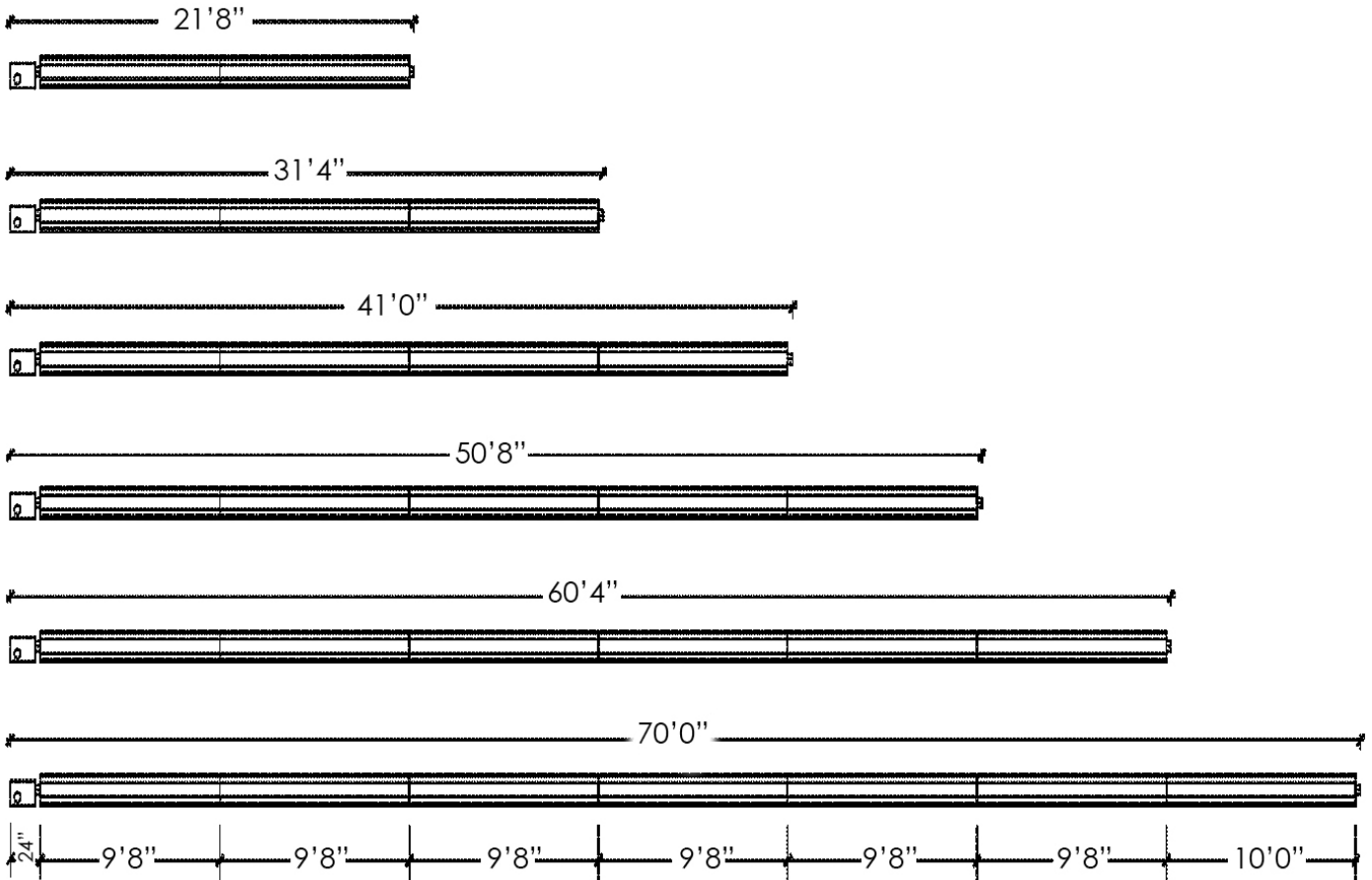

## Clearance to Combustibles:

The clearance to combustible material represents the minimum distance that must be maintained between heater and a nearby combustible surface. The stated clearance to combustibles represents a surface temperature of 90°F (50°C) above room temperature. Some materials such as awnings or plastic may require higher clearances. It is the installer's responsibility to ensure that building materials with a low heat tolerance which may degrade at lower temperature are protected to prevent degradation.

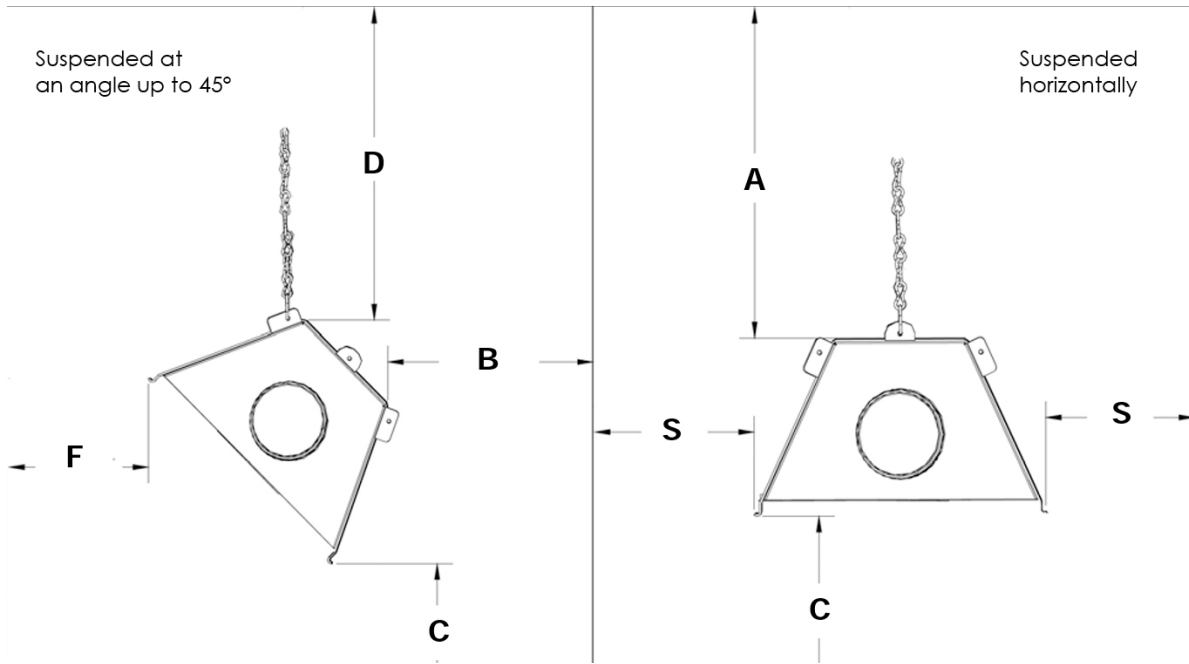

## STW2 Minimum Clearances to Combustibles

### MODEL

SPW Input Rate (BTU/hr)

SUSPENDED AT AN ANGLE UP TO 45 DEGREES

SUSPENDED HORIZONTALLY

Inches	D	B	F	C	A	S	C
STW2-200/140	13"	6"	74"	70"	14"	44"	76"
STW2-175/125	12"	6"	72"	68"	13"	42"	74"
STW2-155/110	5.5"	1"	64"	64"	3.5"	22"	70"
STW2-130/90	4.5"	1"	60"	60"	3.3"	21"	65"
STW2-110/75	3.5"	1"	54"	54"	2"	19"	60"
STW2-80/60	3"	1"	23"	38"	1.75"	6"	38"

## Controls & Control Accessories

Tag	Qty	Item Number	Description
		JM-0504-TKX	Thermocontrol Plus Controller (See Separate Detailed Thermocontrol Plus Submittal Document)
		JS-0570-XX	Moisture Proof Nema 4X Thermostat Single-Stage
		JS-0568-CC	24V Relay Switch. Control Multiple Tube Heaters in a common zone with one 24V Thermostat (wired to 1st heater)
		JP-1236-RK	Remote Control Receiver Kit installs in burner. REQUIRED - Order one for each heater - High-intensity or Tube type
		JP-1236-HS	Hand Set Control (four On/Off buttons): REQUIRED - Order one for every four zones: a zone is 1 or more heaters - Control up to 4 individual heaters or up to 4 zones
		JP-1236-KT	Wireless Remote Control Keypad Transmitter: OPTIONAL - JP-1236-HS Required for master code programming - Control up to four patio zones - 3 Zones with unique 4 digit pin & 1 zone with direct push button - Weather resistant: Outdoor or indoor installation

## Additional Accessories

Tag	Qty	Item Number	Description
		JL-0800-GR-B	Gripple Express™. For indoor use only. No tools required for adjustment. Ready to use 10 ft cable length kit - loop one end. 100 lb work load.
		JL-0800-XX	#2 Lion Chain. 115 lb work load - 200 ft roll.
		JL-0800-SH	Safety Snap Hooks - 2". Package of 24
		JL-0800-SH-B	Safety Snap Hooks - 2". Package of 100
		JL-0798-SH	""S' Hooks - 1 7/8". Quantity of 'S' hooks needed: JZ Series quantity required = ((tube length/10) x 2) + 4 : ie: SPW-JZ x 40 ft = (40/10) x 2) +4 = 12 hooks"
		JL-0798-CS	Clearance to combustibile sign. Metal sign - 18" x 6" - 3/4" red lettering on white background
		JS-0508-JZ	90° Aluminized Steel Elbow & Reflector Cover Kit. Compatible with STS-JZ, STW-JZ, STWS & SPW-JZ tube heater models. Elbow can be installed right or left hand. Includes coupler, reflector cover, hanger plate.
		JA-0528-XX	4" horizontal Flue Vent Terminals. Fits single wall vent pipe - field crimp required to fit to double wall pipe. Use this termination cap by Schwank or use an approved High Wind termination cap as supplied by others.
		JA-0514-XX	Common Flue Vent Tee Box Roof Termination: Use approved cap supplied by manufacturer of double-walled vent pipe. Not available in stainless steel.
		JA-0516-AA	4" x 8" Aluminized Steel Coupler with 2 x U-bolts. Optional Couplers for Vent Tee. ADD TWO optional tube couplers JA-0516-AA if desired for vent pipe connection to Tee.
		TG-0010-KT	Tuxedo Grill Kit   JZ Models ONLY Decorative 'Tuxedo' Grille Kit - 10 ft - Matte Black Grille
		JA-0780-XX	Tube Protection Screen. STS-JZ, STW-JZ, SPW-JZ Models. 5 ft length - 1/2" x 1/2" galvanized screen.
		JS-0509-KT	Reflector Side Extension. All models - 10" deep x 116" long c/w Qty 3 x 'S' hooks

## Additional Items

Tag	Qty	Part #	Description