

Origin™ OMC-F4 Multi-Cook Convection Oven



Electric or Gas

UL

Origin™ Multi-Cook Convection Ovens, powered by Structured Air Technology®, deliver consistent, even cooking with high-velocity vertical airflow. Designed to reduce cook times and provide evenness across all pans, even when fully loaded, with no pan rotation and limited door openings. Origin cooks up to four uniquely timed foods simultaneously using simple controls and individual timers.

Standard Features

- Dependent, double-pane glass door
- One (1) ON/OFF/COOL DOWN switch
- One (1) LOW/HIGH fan speed switch
- Four (4) shelf-specific digital timers (up to 99 minutes each)
- Digital temperature display with actual temperature feature
- Heat-on indicator light
- One (1) ON/OFF chamber light switch
- Sound volume settings: OFF/LOW/HIGH
- One (1) wire shelf per chamber (four [4] total)
- Removable jet plates:
 - For machine-washable, easy cleaning
 - For combining chambers into 2- or 3-chamber cooking
- Wire rack risers for increased cooking speed and roasting
- Smooth-rolling dial to set temperature and time



Shown with 25" [635 mm], adjustable legs



- 4** Four full-size sheet pans
 Eight full-size hotel pans x 4"
 Four full-size hotel pans x 6" with two jet plates removed
 80 lb [36 kg] maximum per shelf

CAPACITY



Temperature range: 100°F to 500°F [38°C to 260°C]

TEMPERATURE



- Top: 20" [508mm]
 Left: 2" [51mm] non-combustible surfaces
 Right: 1" [25mm] non-combustible surfaces
 Back: 1-1/2" [38mm]

CLEARANCE



REQUIREMENTS

- Appliance must be installed level.
- Appliance must be installed under a hood.
- Appliance must not be installed in any area where it may be affected by steam, grease, dripping water, extreme temperatures, or any other severely adverse conditions.
- Appliances with casters and no cord or plug must be secured to the building structure with a flexible connector. Connector not factory supplied.
- The top of the oven is hot during operation. Do not place any items on top of the oven.

Power Choices

- Natural Gas
- Electric

Electrical

- 120V, 50/60Hz, 1Ph, (gas units only)
- 208V, 50/60Hz, 1Ph
- 240V, 50/60Hz, 1Ph
- 208V, 50/60Hz, 3Ph
- 240V, 50/60Hz, 3Ph
- 480V, 50/60Hz, 3Ph

Install Kits

- 120V, 60Hz, 1PH, (gas, single unit) 5039309
- 120V, 60Hz, 1PH, (gas, stacked) 5039314
- 208V, 50/60Hz, 1Ph 5039310
- 240V, 50/60Hz, 1Ph 5039311
- 208V, 50/60Hz, 3Ph 5039312
- 240V, 50/60Hz, 3Ph 5039312
- 480V, 50/60Hz, 3Ph 5039313

Support Options

- 25" [635mm] Leg package 5038559
- 25" [635mm] Leg package with casters 5038918
- 6" [152mm] Seismic leg package 5038659
- 6" [152mm] Adjustable legs 5038658
- 3" [76mm] Caster package 5033325

Stacking Options

- Origin over Origin 5038568
- Prodigy® 7-20 over Origin 5038237
- Prodigy 6-10 over Origin 5038560

Accessories

- Grill pan, 11" x 16" [279mm x 406mm] PN-39135
- Grill pan, 11" x 16" [279mm x 406mm], ribbed PN-39474
- Wire shelf, 12-3/8" x 26-3/4" [314mm x 679mm] SH-48359
- Grilling grate, 12" x 20" [305mm x 508mm] SH-26731
- Oven peel 5030000
- Alto-Shaam® non-caustic cleaner, one [1] bottle CE-46828
- Alto-Shaam non-caustic cleaner, case of six [6] bottles CE-46829



ANSI/NSF 4



COOKING APPLIANCE



ANSI/NSF 4

Origin™ OMC-F4 Multi-Cook Convection Oven



Dimensions—Gas Oven on 25" [635mm] Legs

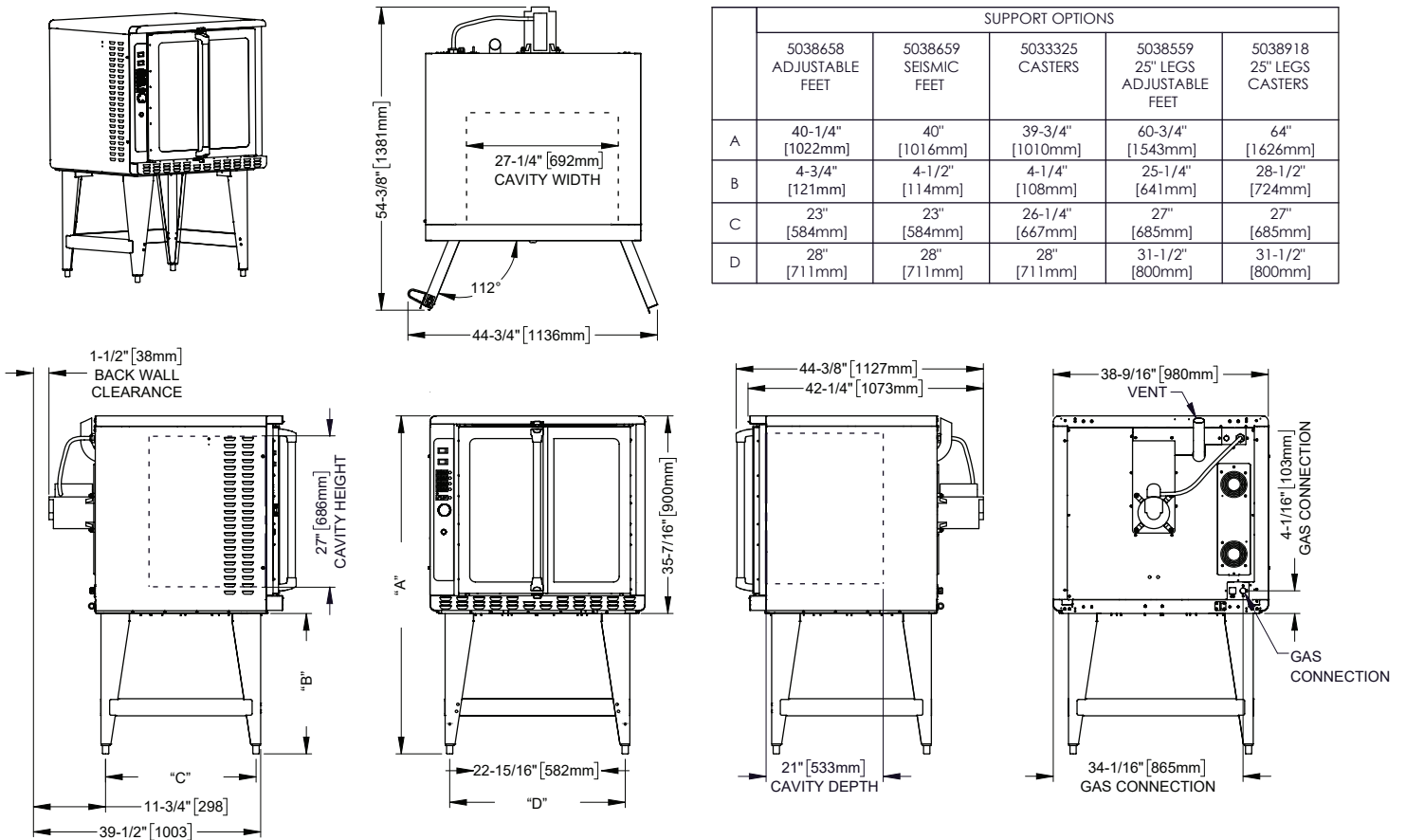

Model **Exterior [H x W x D] with 25" legs** **Interior [H x W x D]**
 OMC-F4 60-3/4" [1543mm] x 38-9/16" [980mm] x 44-3/8" [1127mm] 27" [686mm] x 27-1/4" [692mm] x 21" [533mm]

Ship Dimensions [L x W x H]**
 OMC-F4 56" [1422mm] x 46" [1168mm] x 50" [1270mm]

** Support legs/casters ship uninstalled.

Model **Net Weight** **Shipping Weight**
 OMC-F4G 120V 498 lb [226 kg] 612 lb [278 kg]

Origin™ OMC-F4 Multi-Cook Convection Oven



Dimensions—208V, 240V Electric Oven on 25" (635mm) Legs

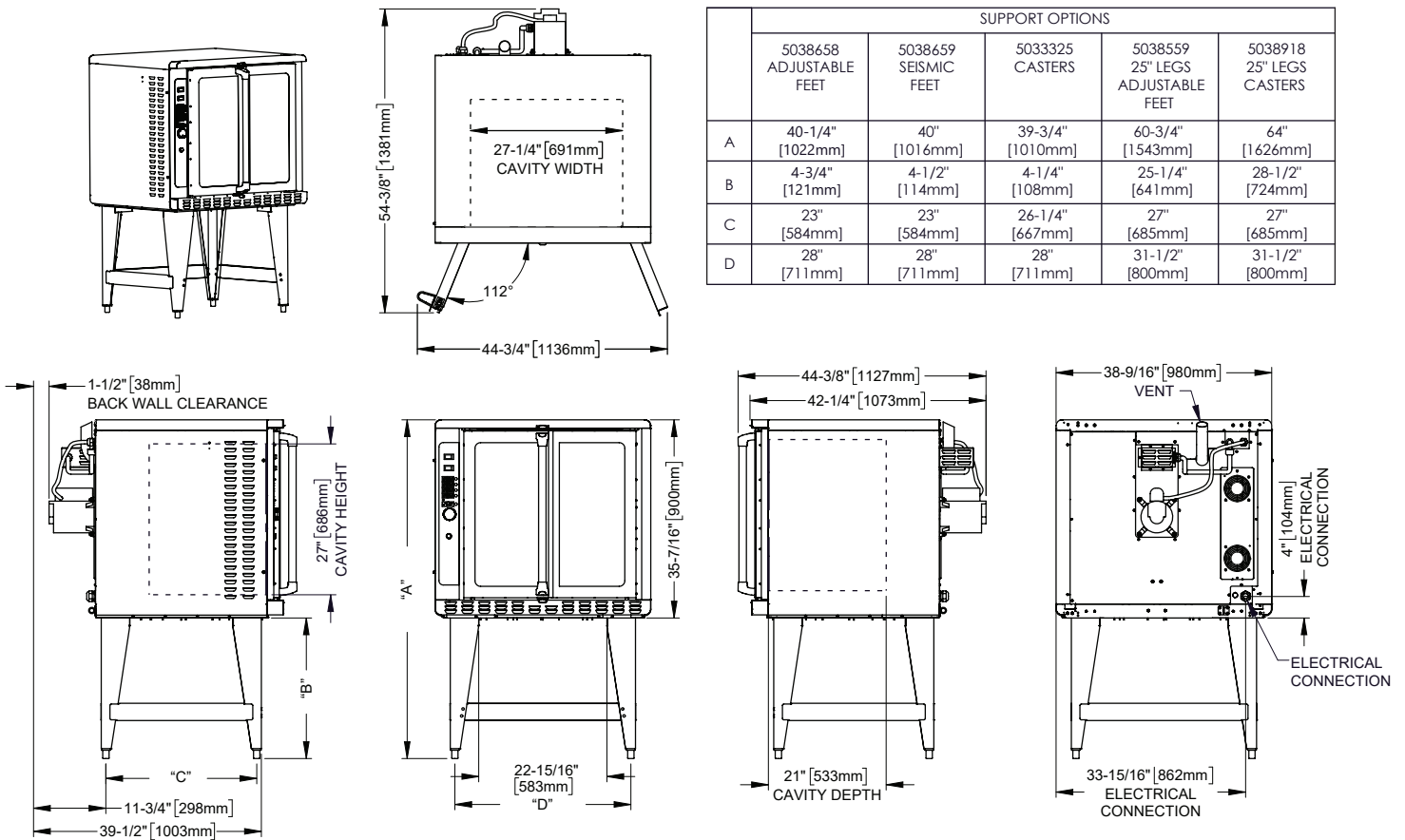

Model **Exterior [H x W x D] with 25" legs** **Interior [H x W x D]**
 OMC-F4 60-3/4" [1543mm] x 38-9/16" [980mm] x 44-3/8" [1127mm] 27" [686mm] x 27-1/4" [692mm] x 21" [533mm]

Ship Dimensions [L x W x H]**
 OMC-F4 56" [1422mm] x 46" [1168mm] x 50" [1270mm]

** Support legs/casters ship uninstalled.

Model **Net Weight** **Shipping Weight**
 OMC-F4E 208/240V 477 lb [216 kg] 591 lb [268 kg]

Dimensions—480V Electric Oven on 25" [634mm] Legs

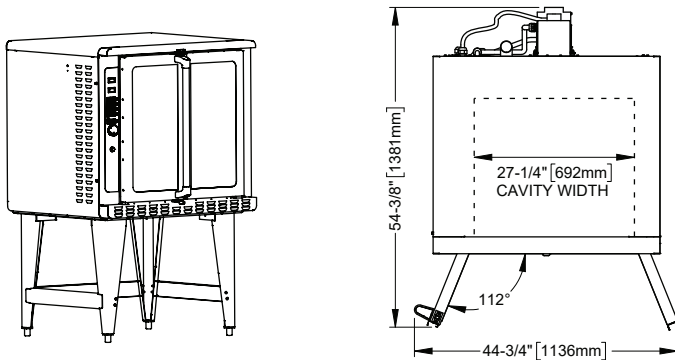

	SUPPORT OPTIONS				
	5038658 ADJUSTABLE FEET	5038659 SEISMIC FEET	5033325 CASTERS	5038559 25" LEGS ADJUSTABLE FEET	5038918 25" LEGS CASTERS
A	40-1/4" [1022mm]	40" [1016mm]	39-3/4" [1010mm]	60-3/4" [1543mm]	64" [1626mm]
B	4-3/4" [121mm]	4-1/2" [114mm]	4-1/4" [108mm]	25-1/4" [641mm]	28-1/2" [724mm]
C	23" [584mm]	23" [584mm]	26-1/4" [667mm]	27" [685mm]	27" [685mm]
D	28" [711mm]	28" [711mm]	28" [711mm]	31-1/2" [800mm]	31-1/2" [800mm]

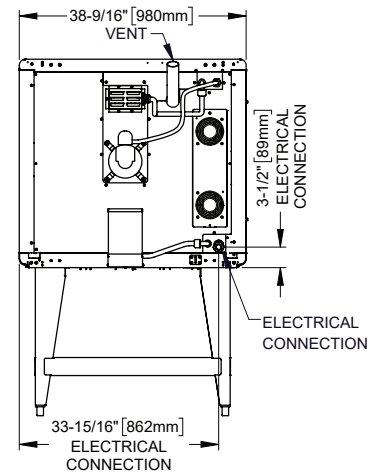
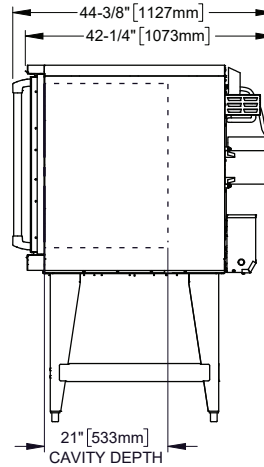
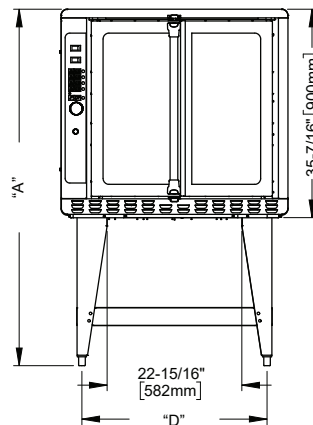
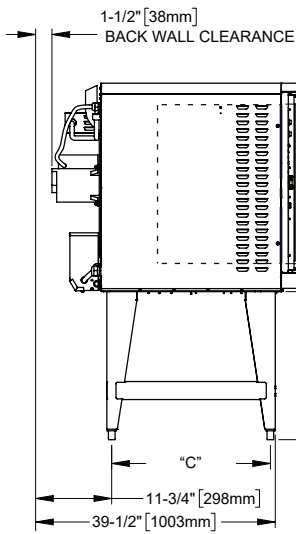

Model **Exterior [H x W x D] with 25" legs** **Interior [H x W x D]**
 OMC-F4 60-3/4" [1543mm] x 38-9/16" [980mm] x 44-3/8" [1127mm] 27" [686mm] x 27-1/4" [692mm] x 21" [533mm]

Ship Dimensions [L x W x H]**
 OMC-F4 56" [1422mm] x 46" [1168mm] x 50" [1270mm]

** Support legs/casters ship uninstalled.

Model	Net Weight	Shipping Weight
OMC-F4E 480V	498 lb [226 kg]	612 lb [278 kg]

Dimensions—Origin over Origin Stack

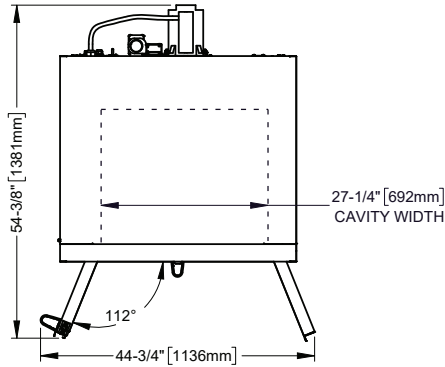

	ORIGIN OVER ORIGIN SUPPORT OPTIONS		
	5038658 ADJUSTABLE FEET	5038659 SEISMIC FEET	5033325 CASTERS
A	75-3/4" [1924mm]	75-1/2" [1918mm]	75-1/4" [1911mm]
B	4-3/4" [121mm]	4-1/2" [114mm]	4-1/4" [108mm]
C	23" [584mm]	23" [584mm]	26-1/4" [667mm]
D	28" [711mm]	28" [711mm]	28" [711mm]

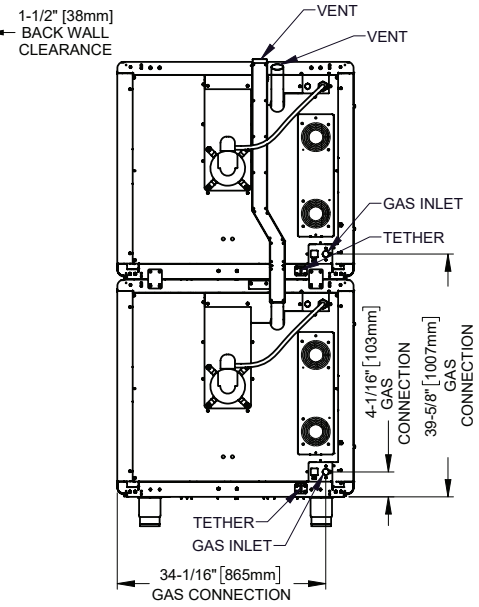
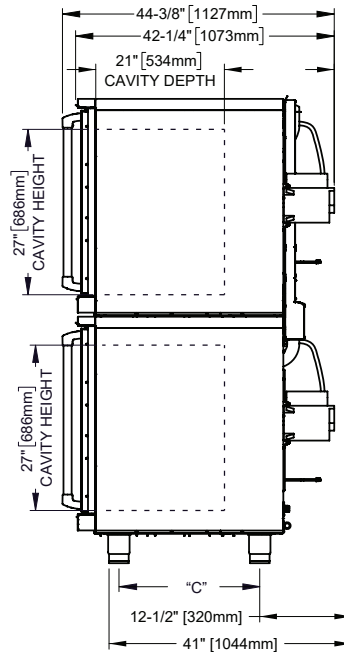
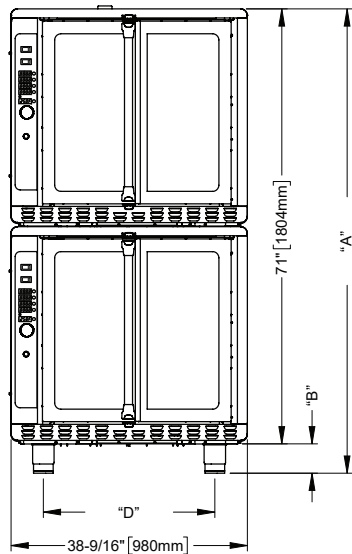

Model OMC-F4
Exterior [H x W x D] overall 75-3/4" [1909mm] x 38-9/16" [980mm] x 44-3/8" [1127mm]

Interior [H x W x D] per oven 27" [686mm] x 27-1/4" [692mm] x 21" [533mm]

Ship Dimensions [L x W x H]**
 OMC-F4 56" [1422mm] x 46" [1168mm] x 50" [1270mm]

** Ovens ship unstacked and support legs/casters uninstalled.

Model	Net Weight	Shipping Weight
OMC-F4G 120V	498 lb [226 kg]	612 lb [278 kg]

Dimensions—Prodiği 6-10 over Origin

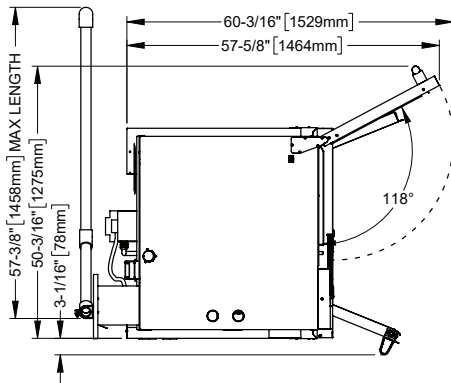

6-10 OVER ORIGIN SUPPORT OPTIONS			
	5038658 ADJUSTABLE FEET	5038659 SEISMIC FEET	5033325 CASTERS
A	75-3/4" [1924mm]	75-1/2" [1918mm]	75-1/4" [1911mm]
B	4-3/4" [121mm]	4-1/2" [114mm]	4-1/4" [108mm]
C	23" [584mm]	23" [584mm]	26-1/4" [667mm]
D	28" [711mm]	28" [711mm]	28" [711mm]

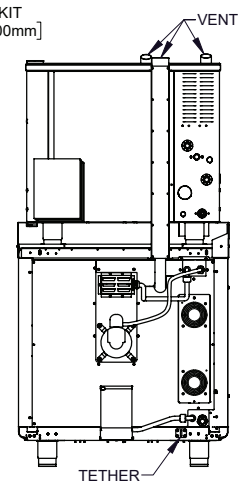
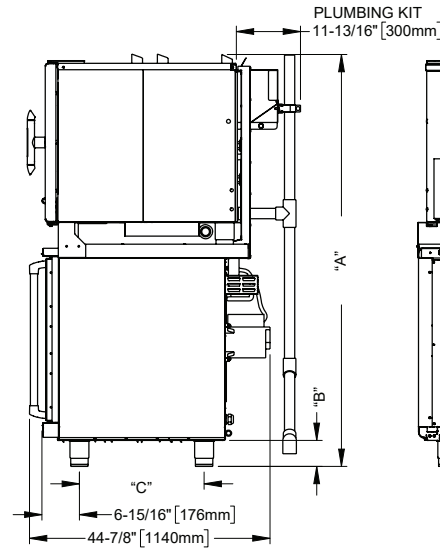
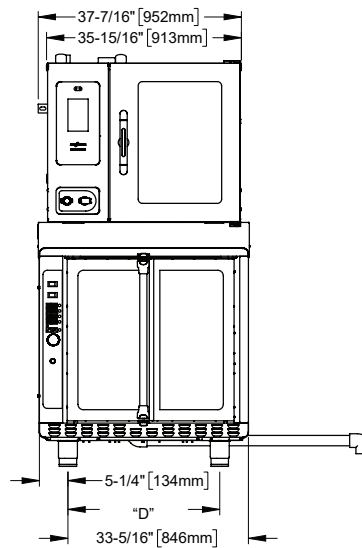
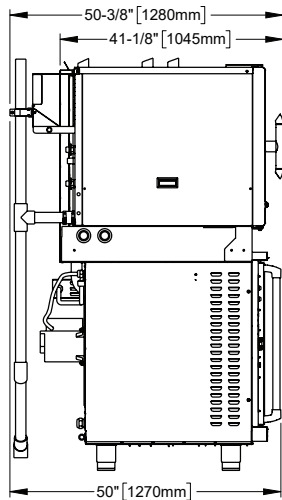

Model

Prodiği 6-10 over Origin

Exterior (H x W x D) overall

75-3/4" [1924mm] x 37-7/16" [952mm] x 50-3/8" [1280mm]

Origin: Interior (H x W x D)

27" [686mm] x 27-1/4" [692mm] x 21" [533mm]

Prodiği 6-10: Interior (H x W x D)

20-1/2" x 16-1/4" x 28-1/16" [521mm x 413mm x 713mm]

Origin: Ship Dimensions (L x W x H)**

56" [1422mm] x 46" [1168mm] x 50" [1270mm]

Prodiği 6-10: Ship Dimensions (L x W x H)**

56" x 45" x 51" [1422mm x 1143mm x 1295mm]

** Ovens ship unstacked and support legs/casters uninstalled.

Model

OMC-F4G 120V

Net Weight

498 lb [226 kg]

Shipping Weight

612 lb [278 kg]

Model

Prodiği 6-10

Net Weight

369 lb [167 kg]

Shipping Weight

508 lb [230 kg]

Dimensions—Prodiği 7-20 over Origin

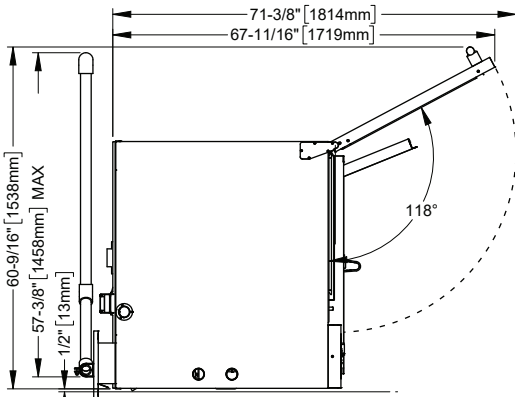

7-20 OVER ORIGIN SUPPORT OPTIONS			
	5038658 ADJUSTABLE FEET	5038659 SEISMIC FEET	5033325 CASTERS
A	78-3/4" [2000mm]	78-1/4" [1988mm]	78" [1981mm]
B	4-3/4" [121mm]	4-1/2" [114mm]	4-1/4" [108mm]
C	23" [584mm]	23" [584mm]	26-1/4" [667mm]
D	28" [711mm]	28" [711mm]	28" [711mm]

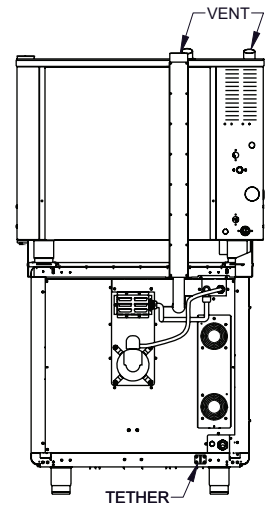
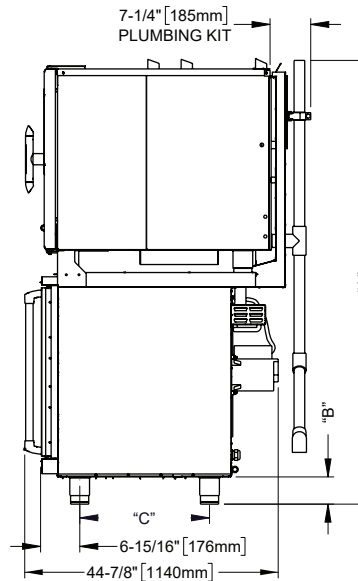
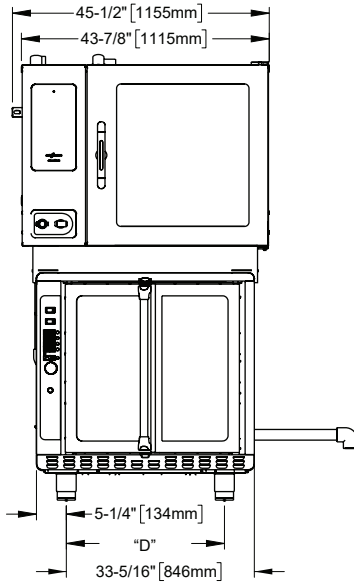
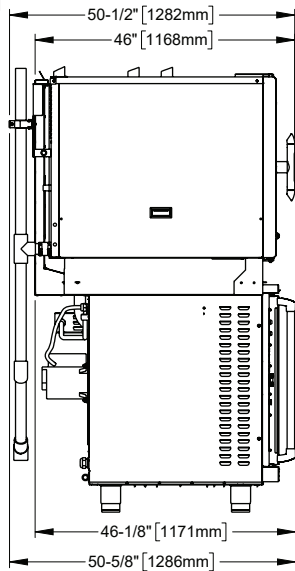

Model

Prodiği 7-20 over Origin

Exterior (H x W x D) overall

78-3/4" [2000mm] x 49-7/16" [1256mm] x 50-1/2" [1282mm]

Origin: Interior (H x W x D)

27" [686mm] x 27-1/4" [692mm] x 21" [533mm]

Prodiği 7-20: Interior (H x W x D)

23-1/4" x 24-1/4" x 32-3/4" [591mm x 616mm x 832mm]

Origin: Ship Dimensions (L x W x H)**

56" [1422mm] x 46" [1168mm] x 50" [1270mm]

Prodiği 7-20: Ship Dimensions (L x W x H)**

56" x 45" x 51" [1422mm x 1143mm x 1295mm]

** Ovens ship unstacked and support legs/casters uninstalled.

Model

OMC-F4G 120V

Net Weight

498 lb [226 kg]

Shipping Weight

612 lb [278 kg]

Model

Prodiği 7-20

Net Weight

563 lb [255 kg]

Shipping Weight

708 lb [321 kg]

Connections—Prodigy over Origin

6-10 OVER ORIGIN

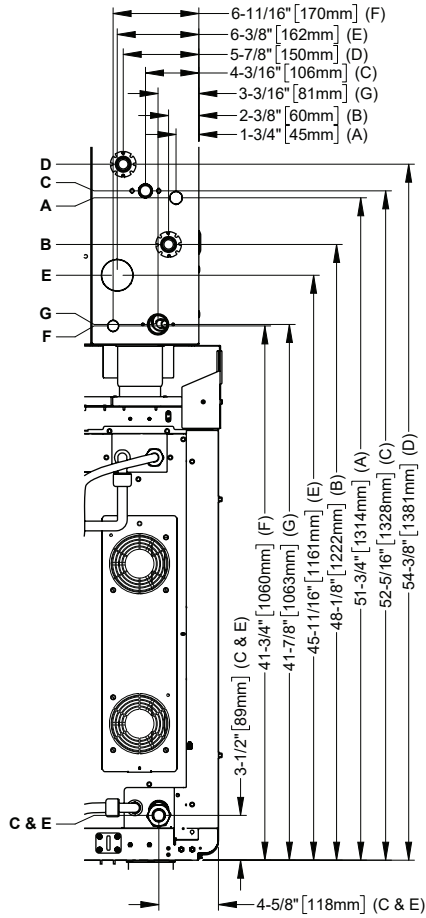

DETAIL X

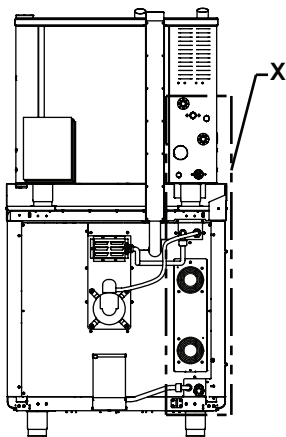

7-20 OVER ORIGIN

- A: ETHERNET
- B: TREATED WATER
- C: GAS CONNECTION
- D: UNTREATED WATER
- E: ELECTRICAL CONNECTION
- F: LIQUID CLEAN
- G: DRAIN

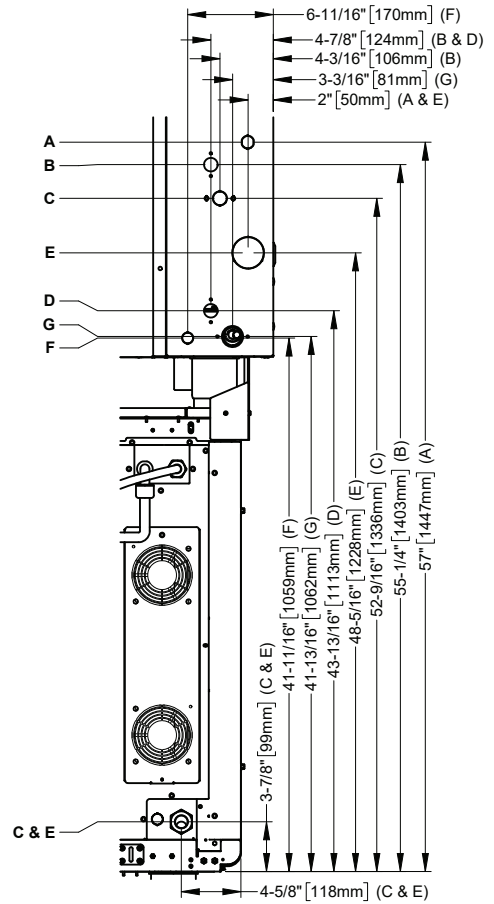

DETAIL Y

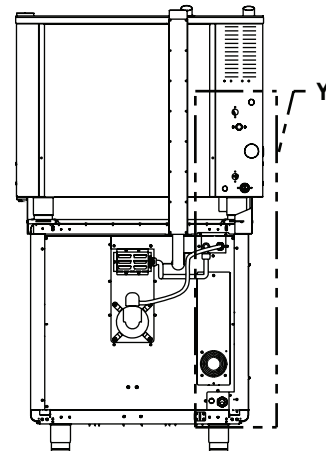

Power Specifications for Electric Models

Volts (VAC)	Power (KW)	Power (AMP)	Hz	Phase	Minimum* Breaker (AMP)	Wire Size (AWG)	CORD/PLUG	Connections
208	10.7	52	50/60	1	65	4	4/3	1Ø/PE
							No cord or plug	
240	10.7	45	50/60	1	60	6	6/3	1Ø/PE
							No cord or plug	
208	10.7	30	50/60	3	40	8	8/4	3Ø/PE
							No cord or plug	
240	10.7	26	50/60	3	35	8	8/4	3Ø/PE
							No cord or plug	
480	10.7	13	50/60	3	20	12	12/4	3Ø/PE
							No cord or plug	

*Compatibility with Class A GFCIs

Power Specifications for Gas Models

Volts (VAC)	Power (KW)	Power (AMP)	Hz	Phase	Minimum* Breaker (AMP)	Wire Size (AWG)	CORD/PLUG	Connections
120	0.80	6.4	50/60	1	15	14	14/3	1Ø/PE
							5-15P	

*Compatibility with Class A GFCIs

Fuel Specifications for Gas Models

UL Marked Appliances	Maximum Input BTU/h	Recommended Outlet Pressure Inches WC (kPa)	Maximum Inlet Pressure Inches WC (kPa)	Minimum Inlet Pressure Inches WC (kPa)	Maximum Fuel Consumption*
					CFH
Natural Gas	50,000	3.5 [0.87]	14.0 [3.5]	5.5 [1.1]	48.2

*Assumes an average heating value for natural gas to be 1050 BTU/SCF and a specific gravity of 0.60. The assumed value for propane gas is 2,500 BTU/SCF, and a specific gravity of 1.53.

Accessories for gas unit

- CR-33543, Dormont 3/4" gas kit.



HEAT: ELECTRIC

Heat of rejection

OMC-F4E	Heat Gain qs, BTU/hr	Heat Gain qs, kW
	1232	0.361



NOISE: ELECTRIC

Noise emissions

Does not exceed 75 dBA when measured at 3.3 ft [1 m] from unit.



HEAT: GAS

Heat of rejection

OMC-F4G	Heat Gain qs, BTU/hr	Heat Gain qs, kW
	1080	0.317



NOISE: GAS

Noise emissions

Does not exceed 75 dBA when measured at 3.3 ft [1 m] from unit.

CONTACT US

W164 N9221 Water Street | Menomonee Falls, Wisconsin 53051 | U.S.A.
 Phone: 262.251.3800 | 800.558.8744 U.S.A./Canada | Fax: 262.251.7067 | alto-shaam.com