

Project:  
Item Number:  
Quantity:

## VERTICAL CONTACT BUN TOASTERS VCBT4



### DESCRIPTION

Vollrath® Vertical Contact Bun Toasters deliver toasted hamburger buns with smooth, evenly-browned cut sides that hold up to juicy burgers, sauces, and sandwiches. The vertical design saves space on the flat top by moving bun toasting to the countertop.

Units accommodate a variety of buns due to a wide range of adjustable heights for crowns and heels—while powerful wattage means high throughput of up to 2,200 buns per hour for some models. This toaster is ideal for foodservice operations that need mid- to high-volume toasting.

### AGENCY LISTINGS



### CLEARANCE

- This unit should be installed adjacent to non-combustible surfaces in a flat location.
- Ensure unit is level to avoid damage during operation.
- Ambient temperatures must be at or below 104 °F (40 °C).
- To avoid damage, plug the unit into a properly grounded electrical supply that matches the nameplate rating.

*Due to continued product improvement, please consult [vollrathfoodservice.com](http://vollrathfoodservice.com) for current product specifications.*

### ITEMS

| Item      | Model | Description   |
|-----------|-------|---|
| VCBT4-208 | CBT15 | VCBT4 208V, variable speed & heat controls, silicone belts, auxiliary bun warmers |
| VCBT4-240 | CBT15 | VCBT4 240V, variable speed & heat controls, silicone belts, auxiliary bun warmers |

| Item    | Accessory for All Models                               |
|---------|--|
| B401850 | Stainless Steel Butter Wheel and Pan (sold separately) |
| B401226 | Bun Feeder (sold separately)                           |
| B401325 | Replacement Release Sheets                             |
| B400506 | (2) Silicone Belt Wraps                                |

### FEATURES & BENEFITS

- Two openings provide maximum loading capacity.
- Adjustable bun-compression settings from ½" up to 1¾" (1.3 up to 4.4 cm) minimize crushing of delicate buns.
- Silicone belt wraps minimize bun marking to improve presentation.
- 350 °F–550 °F ( 176.7 °C–287.8 °C) temperature range allows precise toasting and browning.
- Dual-sided platen heater retains heat and provides smoothly-toasted buns that hold up to juicy burgers and sauces.
- Auxiliary heaters warm tops and bottoms of buns.
- Highest speed setting puts buns through in 10 seconds.
- Unit is easy to clean with no tools required—loosen captive fasteners to easily remove top cover and open front and back of toaster for cleaning.
- Controls are simple to use.
- Included Release Sheets (2) are easy to clean and install and allow buns to move through the toaster without sticking.
- Optional Butter Wheel and Bun Feeder enhance convenience and efficiency and are easy to remove and clean.
- Butter Wheel (sold separately) attaches to the top of the toaster without tools and keeps melted butter warm.
- Bun Feeder (sold separately) is slightly angled and gravity fed to make preloading buns quick and easy.
- High wattage preheats unit quickly and increases throughput.
- Fan automatically runs until unit is completely cool.
- Stainless steel components are durable and easy to clean.
- 6' (1.8 m) cord with plug allows placement options.
- Units are Made in the USA.

### WARRANTY

- Warrantied Parts: 2 years parts, 1 year labor
- For warranty period, exclusions, and details, visit [vollrathfoodservice.com/vollrath-resources/warranty-info/warranty-policy](http://vollrathfoodservice.com/vollrath-resources/warranty-info/warranty-policy).

**DIMENSIONS** inches [cm]

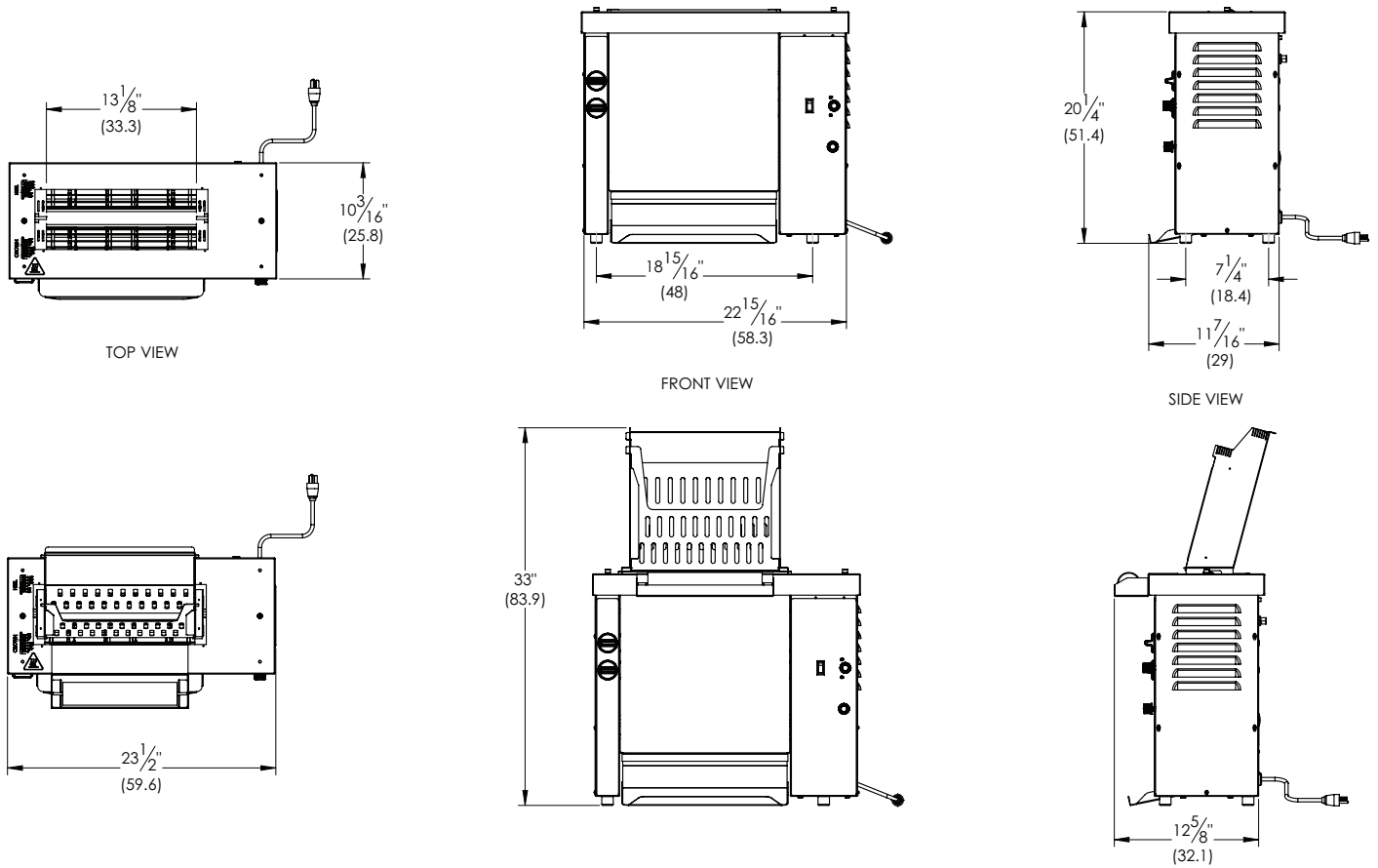

**SPECIFICATIONS**

| Item      | Description   | Volts | Watts | Amps | Capacity           | Pass-Through Time      | Shipping Weight & Dimensions (Including Pallet) |             |             |             | Plug & Receptacle  |
|-----------|---|-------|-------|------|--------------------|------------------------|---|-------------|-------------|-------------|--|
|           |   |       |       |      |                    |                        | Weight lb (kg)                                  | W in. (cm)  | H in. (cm)  | D in. (cm)  |  |
| VCBT4-208 | VCBT4 208V, variable speed & heat controls, silicone belts, auxiliary bun warmers | 208   | 3300  | 16.0 | Up to 2200 buns/hr | 10–35 Second, Variable | 84 (38.1)                                       | 28.3 (71.8) | 26.8 (68.1) | 15.5 (39.4) | 6-20P & R<br> |
| VCBT4-240 | VCBT4 240V, variable speed & heat controls, silicone belts, auxiliary bun warmers | 240   |       | 13.8 |                    |                        |   |             |             |             |  |

\*Toast time is dependent upon power frequency.



The Vollrath Company, L.L.C.  
 1236 North 18th Street  
 Sheboygan, WI 53081-3201 U.S.A.  
 Main Tel: 800.624.2051 or 920.457.4851  
 Main Fax: 800.752.5620 or 920.459.6573  
 Customer Service: 800.628.0830  
 Canada Customer Service: 800.695.8560

Technical Services  
 techservicereps@vollrathco.com  
 Induction Products: 800.825.6036  
 Countertop Warming Products: 800.354.1970  
 All Other Products: 800.628.0832