

# VOLLRATH®

Project:

Item Number:

Quantity:

## VERTICAL CONTACT BUN TOASTERS VCBT2



### DESCRIPTION

Vollrath® Vertical Contact Bun Toasters deliver toasted hamburger buns with smooth, evenly-browned cut sides that hold up to juicy burgers, sauces, and sandwiches. The vertical design saves space on the flat top by moving bun toasting to the countertop.

Units accommodate a variety of buns due to a wide range of adjustable heights for crowns and heels—while powerful wattage means high throughput of up to 2,200 buns per hour for some models. This toaster is ideal for foodservice operations that need mid- to high-volume toasting.

### AGENCY LISTINGS



### CLEARANCE

- This unit should be installed adjacent to non-combustible surfaces in a flat location.
- Ensure unit is level to avoid damage during operation.
- Ambient temperatures must be at or below 104 °F (40 °C).
- To avoid damage, plug the unit into a properly grounded electrical supply that matches the nameplate rating.

*Due to continued product improvement, please consult [vollrathfoodservice.com](http://vollrathfoodservice.com) for current product specifications.*

### ITEMS

Item	Model	Description
VCBT2-120-20	CBT15	VCBT2 120V, 20 second fixed speed, variable heat control, wire belts
VCBT2-120-35	CBT15	VCBT2 120V, 35 second fixed speed, variable heat control, wire belts
VCBT2-208	CBT15	VCBT2 208V, variable speed & heat controls, wire belts
VCBT2-240	CBT15	VCBT2 240V, variable speed & heat controls, wire belts

Item	Accessory for All Models
B401850	Stainless Steel Butter Wheel and Pan (sold separately)
B401226	Bun Feeder (sold separately)
B401325	Replacement Release Sheets
B400506	(2) Silicone Belt Wraps (sold separately)

### FEATURES & BENEFITS

- Two openings provide maximum loading capacity.
- Adjustable bun-compression settings from 1/2" up to 1 3/4" (1.3 up to 4.4 cm) minimize crushing of delicate buns.
- 350 °F–550 °F ( 176.7 °C–287.8 °C) temperature range allows precise toasting and browning.
- Dual-sided platen heater retains heat and provides smoothly-toasted buns that hold up to juicy burgers and sauces.
- Wire belt is low maintenance and long lasting.
- Unit is easy to clean with no tools required—loosen captive fasteners to easily remove top cover and open front and back of toaster for cleaning.
- Controls are simple to use.
- Included Release Sheets (2) are easy to clean and install and allow buns to move through the toaster without sticking.
- Silicone belt wraps (sold separately) minimize bun marking to improve presentation.
- Optional Butter Wheel and Bun Feeder enhance convenience and efficiency and are easy to remove and clean.
- Butter Wheel (sold separately) attaches to the top of the toaster without tools and keeps melted butter warm.
- Bun Feeder (sold separately) is slightly angled and gravity fed to make preloading buns quick and easy.
- High wattage preheats unit quickly and increases throughput.
- Fan automatically runs until unit is completely cool.
- Stainless steel components are durable and easy to clean.
- 6' (1.8 m) cord with plug allows placement options.
- Units are Made in the USA.

### WARRANTY

- Warrantied Parts: 2 years parts, 1 year labor.  
For warranty period, exclusions, and details, visit [vollrathfoodservice.com/vollrath-resources/warranty-info/warranty-policy](http://vollrathfoodservice.com/vollrath-resources/warranty-info/warranty-policy).

**DIMENSIONS** inches [cm]

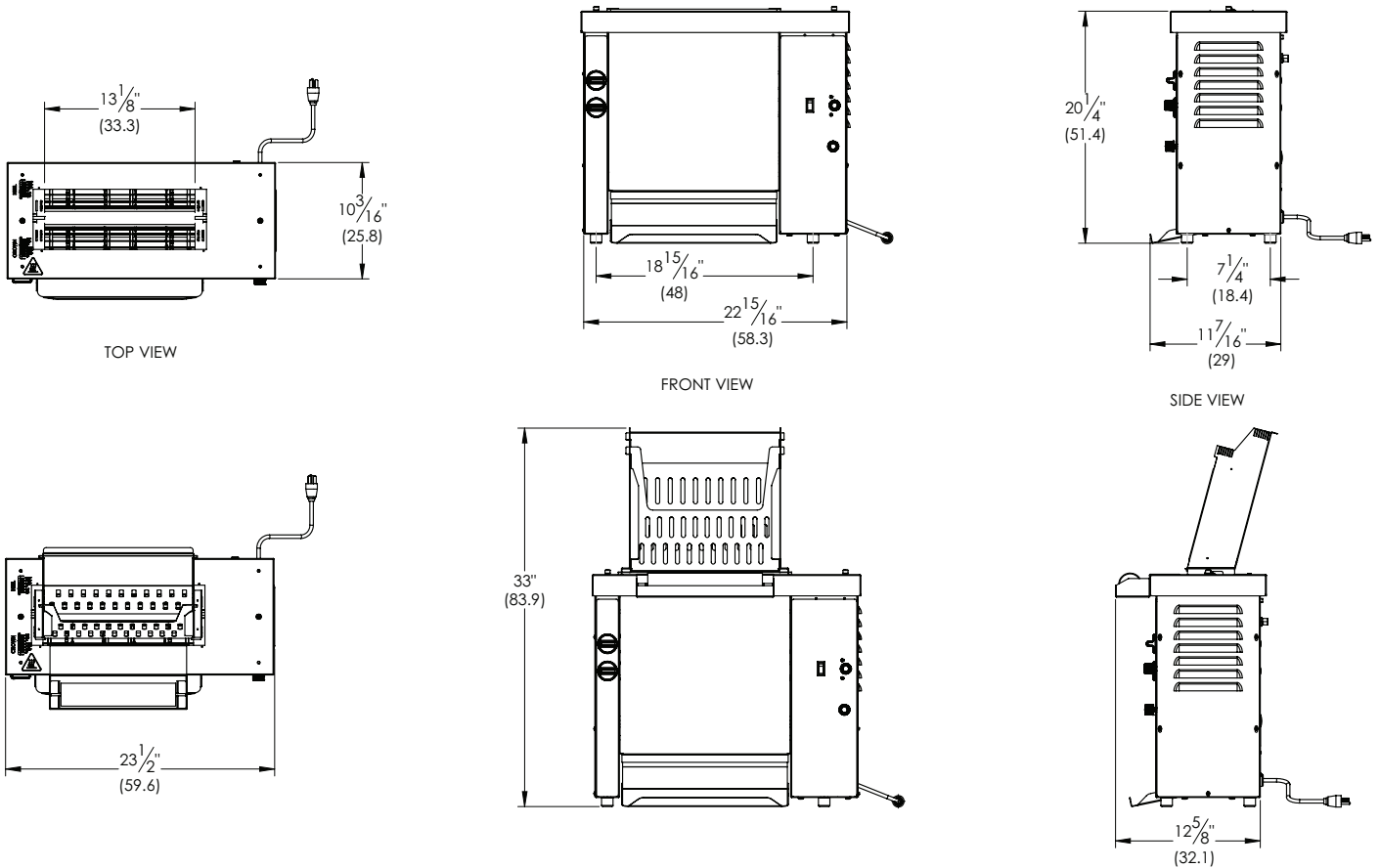

**SPECIFICATIONS**

Item	Description	Volts	Watts	Amps	Capacity	Pass-Through Time	Shipping Weight & Dimensions (Including Pallet)				Plug & Receptacle				
							Weight lb (kg)	W in. (cm)	H in. (cm)	D in. (cm)					
VCBT2-120-20	VCBT2 120V, variable heat control, wire belts	120	1440	12	Up to 1100 buns/hr	20-Second, Fixed	84 (38.1)	28.3 (71.8)	26.8 (68.1)	15.5 (39.4)	5-15P & R 				
VCBT2-120-35	VCBT2 120V, variable heat control, wire belts				Up to 630 buns/hr	35-Second, Fixed									
VCBT2-208	VCBT2 208V, variable speed & heat controls, wire belts	208	2400	11.5	Up to 2200 buns/hr	10-35 Second, Variable					84 (38.1)	28.3 (71.8)	26.8 (68.1)	15.5 (39.4)	6-20P & R 
VCBT2-240	VCBT2 240V, variable speed & heat controls, wire belts	240		10.0											

\*Toast time is dependent upon power frequency.



The Vollrath Company, L.L.C.  
 1236 North 18th Street  
 Sheboygan, WI 53081-3201 U.S.A.  
 Main Tel: 800.624.2051 or 920.457.4851  
 Main Fax: 800.752.5620 or 920.459.6573  
 Customer Service: 800.628.0830  
 Canada Customer Service: 800.695.8560

Technical Services  
 techservicereps@vollrathco.com  
 Induction Products: 800.825.6036  
 Countertop Warming Products: 800.354.1970  
 All Other Products: 800.628.0832