



ServIt WDNBI-2 Double Narrow Built-In Drawer Warmer - 900W, 120V

#423WDNB12

FEATURES

- Two drawers fit full size 12" x 20" x 6" food pans
- Full stainless-steel construction and 14-gauge slide brackets help ensure long-lasting durability
- 1" thick fiberglass insulation and built-in drawer gasket keep heat inside for efficient use
- A vent control feature to adjust airflow based on whether foods need to be kept dry or moist
- Thermostatic controls provide an 80-220 degrees Fahrenheit temperature range; 900W, 120V

TECHNICAL DATA

Width	23 7/16 Inches
Depth	29 Inches
Height	22 7/8 Inches
Cutout Width	19 11/16 Inches
Cutout Depth	30 Inches
Cutout Height	19 13/16 Inches
Phase	1 Phase
Voltage	120 Volts
Wattage	900 Watts
Control Type	Thermostatic



CERTIFICATIONS

- NSF Listed
 UL Listed, US
 5-15P

TECHNICAL DATA

Features	NSF Listed
Installation Type	Built-In
Maximum Temperature	220 Degrees F
Number of Drawers	2 Drawers
Plug Type	NEMA 5-15P
Power Type	Electric
Style	Narrow Drawer
Temperature Range	80 - 220 Degrees F
Warmer Style	Stationary

Plan View

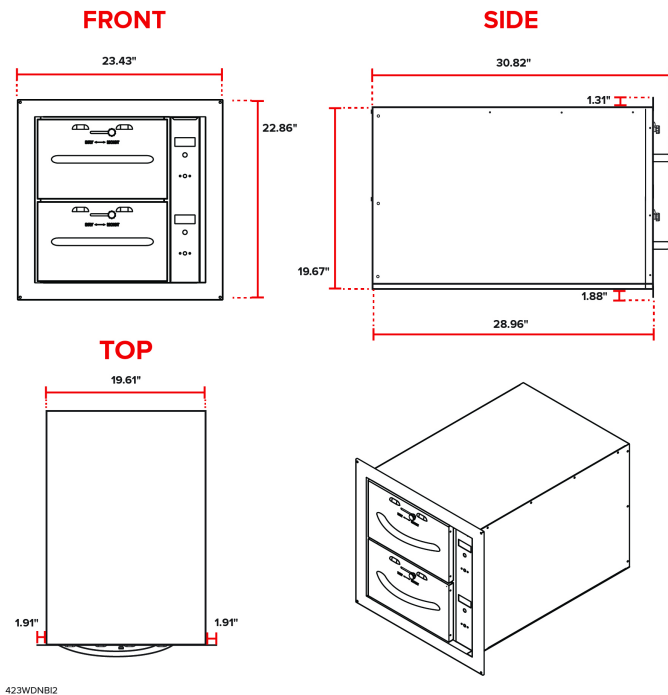

Notes & Details

Keep your most popular sides and entrees hot and ready to serve with the Servit WDNBI-2 double narrow built-in drawer warmer! This warmer features 900 watts of heating power and two drawers that accommodate a full size 12" x 20" x 6" food pan in each drawer that you can fill to the brim with a variety of hot foods. There are also pan supports to accommodate different compatible sizes of food pans in this warmer. The durable, full stainless steel construction makes sure that this drawer warmer will stand up to frequent use while the 1" thick fiberglass insulation and built-in drawer gaskets keeps the heat inside for efficient use.

The built-in design means this warmer won't take up any of your valuable counter space and its narrow, 20 1/4" width makes it an ideal solution for establishments with space limitations. Plus, its 11 gauge drawers slide on 14 gauge slide brackets to help ensure long-lasting durability. Recessed thermostatic temperature controls for each drawer, an indicator lamp, and vent controls allow you to efficiently adjust this warmer to properly keep your best foods hot and ready to eat. The vent control allows ultimate control over airflow for foods to be kept dry, or can be closed to restrict airflow to keep foods moist. The thermostatic controls will automatically turn back on when there is a 3 to 10 degrees Fahrenheit drop in temperature. This drawer warmer boasts a wide temperature range between 80 and 220 degrees Fahrenheit, allowing you to keep a variety of foods at safe temperatures all day. This unit requires a 120V electric connection.

⚠ WARNING: This product can expose you to chemicals including Lead, which are known to the State of California to cause cancer, birth defects, or other reproductive harm. For more information, go to www.p65warnings.ca.gov.