



ServIt GST-4WE-LP Four Pan Open Well Liquid Propane Steam Table with Undershef - 14,000 BTU

#423GST4WELP

FEATURES

- Heavy-duty stainless steel and galvanized leg construction, ensuring durability and reliability
- Holds 4 full size 6" deep food pans; accommodates various pan configurations
- Polyethylene 8" deep cutting board provides plenty of extra work space
- Convenient undershef provides additional space for utensils, pans, or lids
- Independent infinite control knobs for optimum heating versatility; 14,000 BTU

TECHNICAL DATA

Width	57 3/8 Inches
Depth	30 3/16 Inches
Height	34 Inches
Compatible Pan Depth	6 Inches
Cutting Board Depth	8 Inches
Cutting Board Height	1/2 Inch
Well Height	6 1/2 Inches
Assembly Options	Assembly Required
Base Style	Undershef
Color	Silver



CERTIFICATIONS



TECHNICAL DATA

Control Type	Infinite
Gas Connection Size	1/2 Inches
Gauge	16 - 22 Gauge
Material	Stainless Steel / Galvanized Steel
Number of Wells	4
Power Type	Liquid Propane
Stainless Steel Type	Type 304 Type 430
Style	Floor Model Heated
Total BTU	14000 BTU
Type	Stationary
Usage	Indoor
Well Type	Open / Dry Well

Plan View

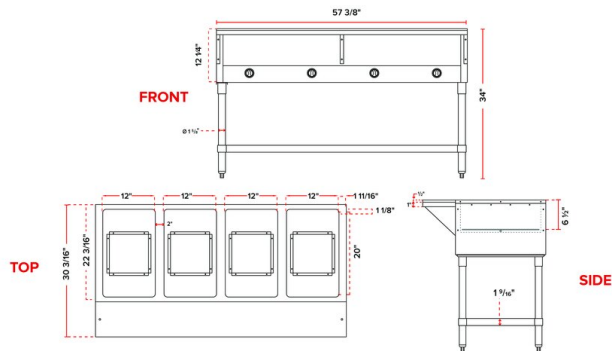

Notes & Details

Keep all of your menu items piping hot and readily available with the ServIt GST-4WE-LP four pan open well liquid propane steam table with undershelf! This powerful holding unit can hold four full size 6" deep food pans full of pasta, meat, or side dishes in each well. The wells can also accommodate various different pan configurations with the use of adapter bars, which allows you to warm multiple foods simultaneously. For all possible configurations, refer to the pan layout diagram. Each well features a high-output burner rated at 3500 BTU. The body of this unit is constructed of durable 22-gauge type 430 stainless steel and heavy-duty hardware. The top and wells are made of 20-gauge type 304 stainless steel, while the cutting board support shelves are made of 16-gauge type 430 stainless steel. Since stainless steel and galvanized steel are resistant to corrosion and rust, you can be sure that this unit will last in a busy restaurant environment if properly cared for.

For quick and efficient start up, this unit features a straight flow, energy-saving burner assembly, with 14,000 BTU total. For optimum heating versatility, each individual well is independently controlled by an infinite control knob. This steam table is intended for dry use, but if you want to use moist heat, try pairing it with compatible spillage pans (sold separately). Simply fill your spillage pan with water and place your food pan inside. The undershelf comes in handy for storing extra serving utensils, food pans, or lids, so all of your most frequently used tools can be close at hand. For extra convenience, the polyethylene 8" deep by 1/2" thick cutting board gives you a little extra work space to prep foods, change out food pans, or fill plates. This open well steam table is a great addition to your commercial establishment.

⚠ WARNING: This product can expose you to chemicals including lead, which are known to the State of California to cause cancer and birth defects or other reproductive harm. For more information, go to www.p65warnings.ca.gov.