

Model: 30HR01XX
Vantage Stainless Steel
Diaper Changing Station

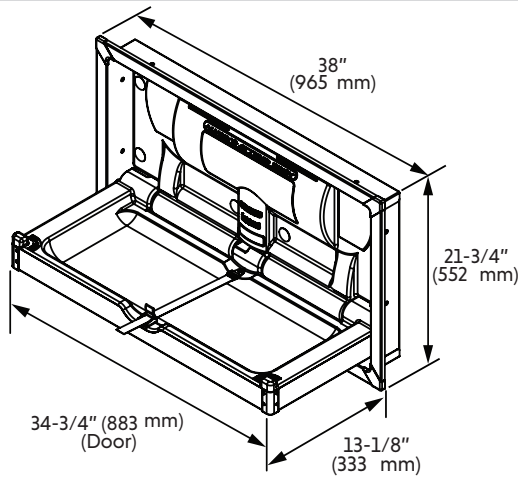

- Polyethylene body with stainless steel exterior
- Easy to clean, high density polyethylene which is naturally bacteria resistant, beneath 304 brushed stainless steel encasement.
- Standard with molded-in dual liner dispensers.
- Each liner dispenser holds approximately 50 of the 05XX0107 or 05XX0207 liners.
- Smooth nylon belt with Thermoplastic Polyurethane coating. Easy to sanitize and adjustable with one hand.
- Convenient bag hooks clearly labeled on both sides
- Easy to read ANSI compliant labels (ANSI Z535.3 and ANSI Z535.4), utilizing universal safety symbols
- Compact, slim profile meets A.D.A. when properly installed. Only protrudes 4 inches or 102 mm from wall.
- Includes universal baby changing station door sign
- Pneumatic gas shock mechanism to ensure smooth, safe open and close motions.
- Includes easy to install, step-by-step instructions plus all mounting hardware
- ASTM G21 Anti-Fungal: No measurable fungal growth
- Meets or exceeds ASTM F2285 Safety Specifications for Commercial Changing Stations.
- Standard pack: 1 unit
- Limited Warranty: This product is warranted against manufacturing defects for a period of 5 years.

Recommended Blocking Recessed Mount

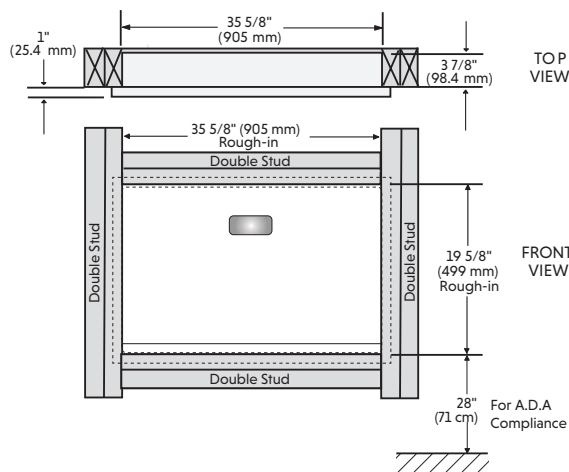

Color Options

- Brushed Stainless
 - 30HR0106
- Matte Black
 - 30HR0109

Installation Information

- 3.88" (98 mm) recessed into wall, 1" (25 mm) protrusion from wall.
- Rough-in opening 35.625" (905mm) wide x 19.625" (499 mm) high. Shim as required for tight fit on all 4 sides. Use side mounting holes.
- Open unit projects from wall 13-1/8" (333 mm).

Short Specifications

Polyethylene Diaper Changing Stations with Stainless Steel Exterior:

1. Acceptable Products: The Sova Company™, Model: Vantage (30HR0106 or 30HR0109).
2. Characteristics: Entire body 18 gauge, 304 brushed stainless steel, seamless welds.
3. Equipped with a pneumatic cylinder.
4. Smooth nylon belt with Thermoplastic Polyurethane coating. Easy to sanitize and adjustable with one hand.
5. Meets ASTM F2285 requirements for weight bearing changing stations.



- 306.3 Knee Clearance
 - 307.2 Maximum Protruding Objects
 - 308.2 Forward Reach
 - 308.3 Side Reach
 - 309.4 Operation
 - 902.3 Work Surface
- Compliant when properly installed.

6. ANSI compliant safety labels
7. CPSIA compliant to applicable sections.