

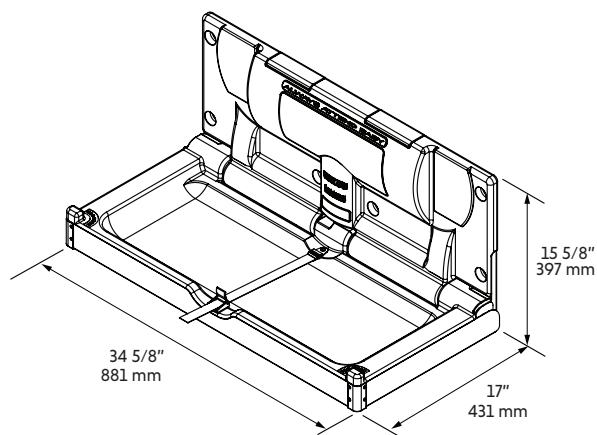

Submittal Sheet

Model: 25HS0X0X Aura Horizontal Diaper Changing Station



34 5/8"
881 mm

15 5/8"
397 mm

17"
431 mm

Recommended Blocking

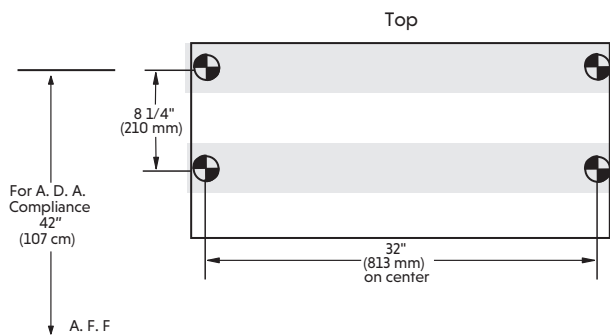

For A. D. A.
Compliance
42"
(107 cm)

8 1/4"
(210 mm)

32"
(813 mm)
on center

Short Specifications

Polyethylene Diaper Changing Stations with Stainless Steel Exterior:

1. Acceptable product: The Sova Company™; Model: Aura (25HS0X0X).
2. Characteristics:
 - a. Type: Molded FDA approved high-density polyethylene (HDPE) body.
 - b. Child protection strap featuring cam-buckle which is adjustable with one hand.
 - c. Smooth nylon belt with Thermoplastic Polyurethane coating. Easy to sanitize and adjustable with one hand.
 - d. Warning labels printed in English, Spanish and French.
 - e. Meets ASTM F2285 requirements for weight bearing Commercial Changing Stations.
 - f. Entire body 18 gauge, 304 brushed stainless steel.
3. A.D.A. Compliance:

	306.3	Knee Clearance
	307.2	Maximum Protruding Objects
	308.2	Forward Reach
	308.3	Side Reach
	309.4	Operation
	902.3	Work Surface

Compliant when properly installed.
4. ANSI compliant safety labels.
5. CPSIA compliant to applicable sections.

- Polyethylene body with stainless steel exterior.
- Easy to clean, high-density polyethylene which is naturally bacteria resistant; beneath 304 brushed stainless steel encasement.
- Standard with molded-in dual liner dispensers.
- Each liner dispenser holds approximately 50 of the 05XX0107 or 05XX0207 liners.
- A.D.A. cam-buckle is adjustable with one hand.
- Smooth nylon belt with Thermoplastic Polyurethane coating. Easy to sanitize and adjustable with one hand.
- Convenient bag hooks clearly labeled on both sides.
- Easy to read ANSI compliant labels (ANSI Z535.3 and ANSI Z535.4), utilizing universal safety symbols.
- Compact, slim profile meets A.D.A. when properly installed. Only protrudes 4 inches or 102 mm from wall.
- Includes universal baby changing station door sign.
- Pneumatic gas shock mechanism to ensure smooth, safe open and close motions.
- Steel-to-steel support hinges.
- Includes easy to install, step-by-step instructions plus all mounting hardware.
- ASTM G21 Anti-Bacterial: No measurable bacterial growth.
- Meets or exceeds ASTM F2285 Safety Specifications for Commercial Changing Stations.
- Standard pack: 1 unit.
- Limited Warranty: This product is warranted against manufacturing defects for a period of 5 years.

Installation Information

- Closed unit projects less than 4 inches (101 mm) from wall.
- Open changing surface projects 17 inches (432 mm) from wall during use.
- Overall closed dimensions are 34-5/8 inches (881 mm) wide and 17 inches (432 mm) tall.
- Hardware allows for mounting to current or new construction applications.