



## Regency 24" x 108" 16-Gauge 304 Stainless Steel Commercial Open Base Work Table

#600WT24108SS



### Technical Data

Length	108 Inches
Width	24 Inches
Height	34 Inches
Work Surface Height	34 Inches
Backsplash	Without Backsplash
Configuration	Straight
Features	Customizable Height NSF Listed
Gauge	16 Gauge
Leg Construction	Stainless Steel

### Features

- 16-gauge type 304 stainless steel top offers greater durability and corrosion-resistance than type 430
- Stainless steel cross bracing adds stability
- 780 lb. weight capacity
- Large table is perfect for multiple workers and a variety of prep tasks
- Adjustable stainless steel bullet feet

### Certifications



## Technical Data

Number of Legs	6 Legs
Size	24" x 108"
Stainless Steel Type	Type 304
Table Style	Open Base
Tabletop Material	Stainless Steel
Top Capacity	780 lb.
Usage	Standard Duty

## Plan View

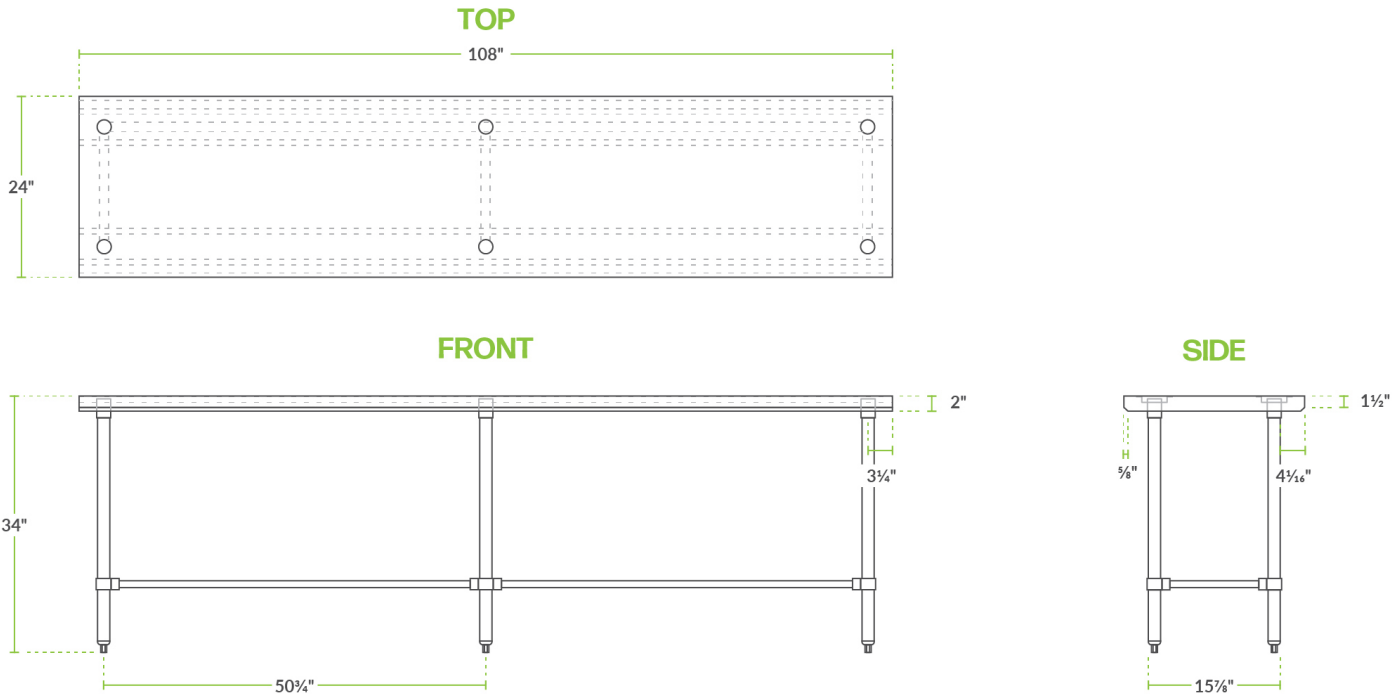

## Notes & Details

This Regency 24" x 108" commercial open base work table is constructed from durable, easy-to-clean 16-gauge type 304 stainless steel. It is designed to provide additional space for food preparation and other tasks within your commercial kitchen. Due to its all-stainless steel construction, this work table is corrosion-resistant and even suited for damp environments.

The six legs and adjustable feet of this work table are also made of tubular stainless steel, ensuring long-lasting performance under heavy use for years to come. The table has a maximum weight capacity of approximately 780 lb. of evenly distributed weight, and it's long enough to accommodate multiple prep workers.

**WARNING:** This product can expose you to chemicals including Lead and Nickel, which are known to the State of California to cause cancer, birth defects, or other reproductive harm. For more information, go to [www.p65warnings.ca.gov](http://www.p65warnings.ca.gov).