

REGENCY
Tables and Sinks

Regency 30" x 30" 16-Gauge Stainless Steel Equipment Stand with Galvanized Undershef

#600ES3030G



Technical Data

Length	30 Inches
Width	30 Inches
Height	26 Inches
Work Surface Height	24 Inches
Backsplash	With Backsplash
Features	Customizable Height NSF Listed With Undershef
Gauge	16 Gauge
Leg Construction	Galvanized Steel

Features

- 16-gauge stainless steel top shelf
- Galvanized steel undershef and legs with adjustable plastic bullet feet
- Perfect for your heavy countertop equipment
- 2" edging keeps equipment from falling off
- 800 lb. top shelf weight capacity; 620 lb. undershef weight capacity

Certifications



Technical Data

Size	30" x 30"
Stainless Steel Type	Type 304
Table Style	Undershelf
Top Capacity	800 lb.
Top Material	Stainless Steel
Type	Equipment Stands
Undershelf Capacity	620 lb.
Undershelf Construction	Galvanized Steel
Usage	Standard Duty

Plan View

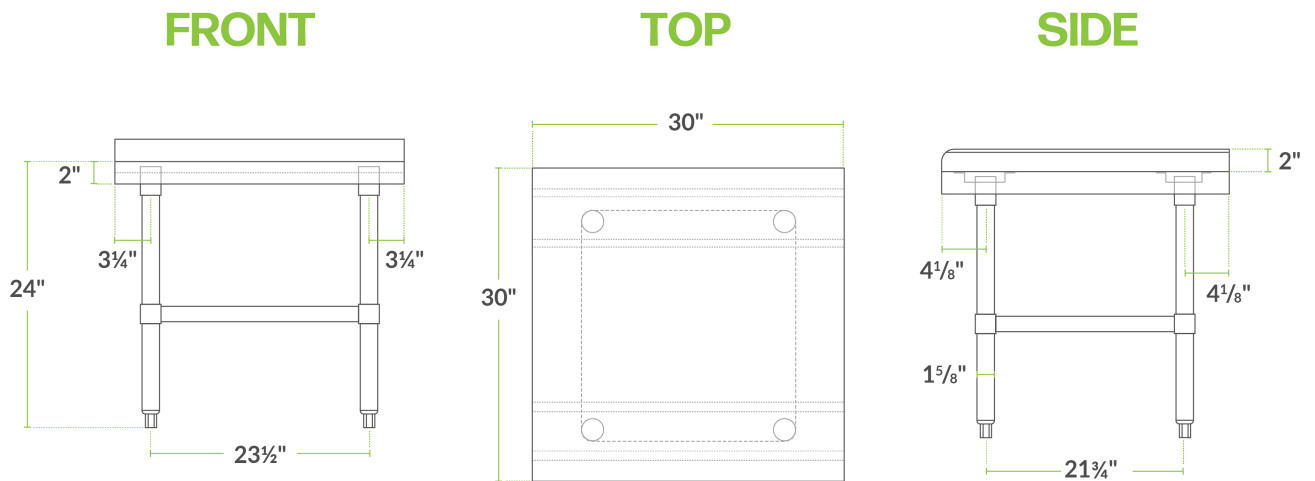

600ES3030G

Notes & Details

This Regency 30" x 30" stainless steel equipment stand is built to stand up to daily use in even the busiest commercial settings! It features a durable 16-gauge type 304 stainless steel top shelf that can support up to 800 lb. of evenly distributed weight, while the galvanized steel undershelf can hold 620 lb.

This stand is ideal for heavy countertop equipment like slushy machines, beverage dispensers, soft serve ice cream machines, and more! A 2" edging comes standard to help contain equipment and contents for added safety. This unit stands on sturdy galvanized steel legs with adjustable plastic bullet feet that allow you to level the stand on uneven surfaces.

⚠️ WARNING: This product can expose you to chemicals including Lead and Nickel, which are known to the State of California to cause cancer, birth defects, or other reproductive harm. For more information, go to www.p65warnings.ca.gov.