



Regency 20 Pan Aluminum Steam Table Pan Rack - Unassembled

#600STPR20KD



Technical Data

Width	16 1/2 Inches
Depth	22 Inches
Height	71 Inches
Assembled	Assembly Required
Capacity	400 lb.
Casters	With Casters
Color	Silver
Individual Shelf Capacity	55 lb.
Loading Style	End Load
Material	Aluminum

Features

- Accommodates up to 20 full size steam table pans
- 16 gauge aluminum angle slides on 3" spaces
- 18 gauge aluminum construction with sturdy 1" x 1" aluminum tubing
- 5" polyurethane casters, 2 with brakes for stability while loading and unloading
- Ships knocked down; easy to assemble

Technical Data

Pan Capacity	20 Pans
Pan Type	Full Size Food Pans
Rack Style	Steam Table
Shelf / Ledge Spacing	3 Inches
Style	Open
Type	Full Height

Plan View

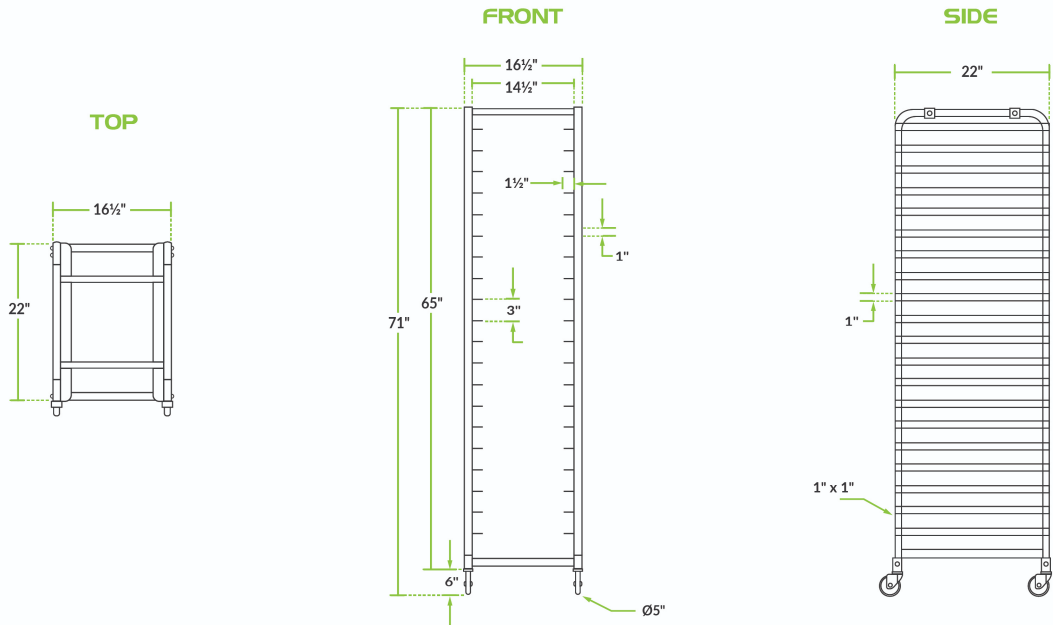

Notes & Details

Keep the back-of-house operating smoothly with this Regency 20 pan aluminum steam table pan rack. Holding up to 20 full size steam table pans in 3" intervals, the rack is perfect for a variety of businesses, from hotels and conference centers to cafeterias and diners.

Built with 18 gauge aluminum, the rack features a sturdy, tubular design with 1" x 1" tubing. The angle slides are made with 16 gauge aluminum for added strength, supporting even fully loaded steam table and hotel pans. For easy transport throughout your facility, this rack features a set of 5" polyurethane casters, 2 of which include brakes. The brakes help to stabilize the rack while you load or unload product. To save on shipping, this rack ships knocked down and is easy to assemble.

⚠ WARNING: This product can expose you to chemicals including lead, which are known to the State of California to cause cancer, birth defects, or other reproductive harm. For more information, go to www.p65warnings.ca.gov.