



Regency CANRK162 Full Size Stationary Aluminum Can Rack for #10 and #5 Cans

#600CANRK162



Technical Data

Length	35 Inches
Width	25 Inches
Height	72 Inches
Capacity	162 Cans
Casters	Without Casters
Features	NSF Listed
Installation Type	Stationary
Material	Aluminum
Style	Full Size
Type	Can Racks

Features

- Holds (162) #10 cans or (216) #5 cans
- Made of fully welded 1 1/2" tubular aluminum
- Stationary, free-standing design may be loaded from the front or back
- Ships fully assembled
- Great for restaurants, retirement facilities, and hospitals

Certifications



Plan View

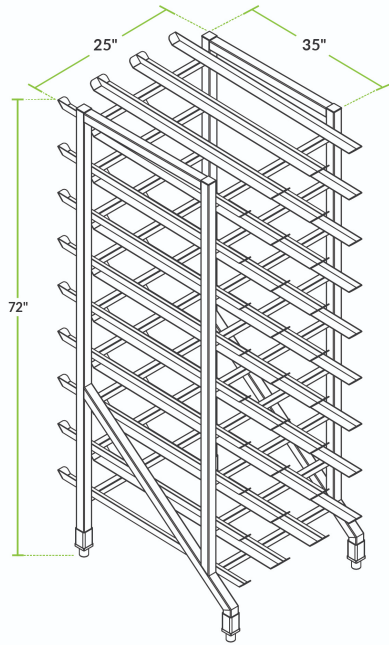

Notes & Details

This Regency CANRK162 full size stationary aluminum can rack for #10 and #5 cans is an ideal choice for restaurants, hospitals, retirement communities, schools, and other food service businesses that need to store large numbers of food cans! Designed to hold up to (162) #10 cans or (216) #5 cans, this unit can be loaded from the front or the rear so your staff can utilize a first in, first out system for stock rotation.

Made of all-welded, 1 1/2" aluminum tubing, this can rack is built to take a beating in your commercial or institutional environment. Additionally, it features angled can guides that allow cans to roll to the front of the unit for easy access. This can rack ships assembled so that you can immediately start using it to organize your storage space.

⚠ WARNING: This product can expose you to chemicals including lead, which are known to the State of California to cause cancer, birth defects, or other reproductive harm. For more information, go to www.p65warnings.ca.gov.