



## Regency PTRAP 13" Chrome P-Trap - 1 1/2" IPS

#600PTRAP



### Technical Data

Type

Traps

### Features

- 22 gauge chrome construction
- 1 1/2" IPS drain connection
- 13" long
- Prevents sewage gases from escaping the drain pipe

Plan View

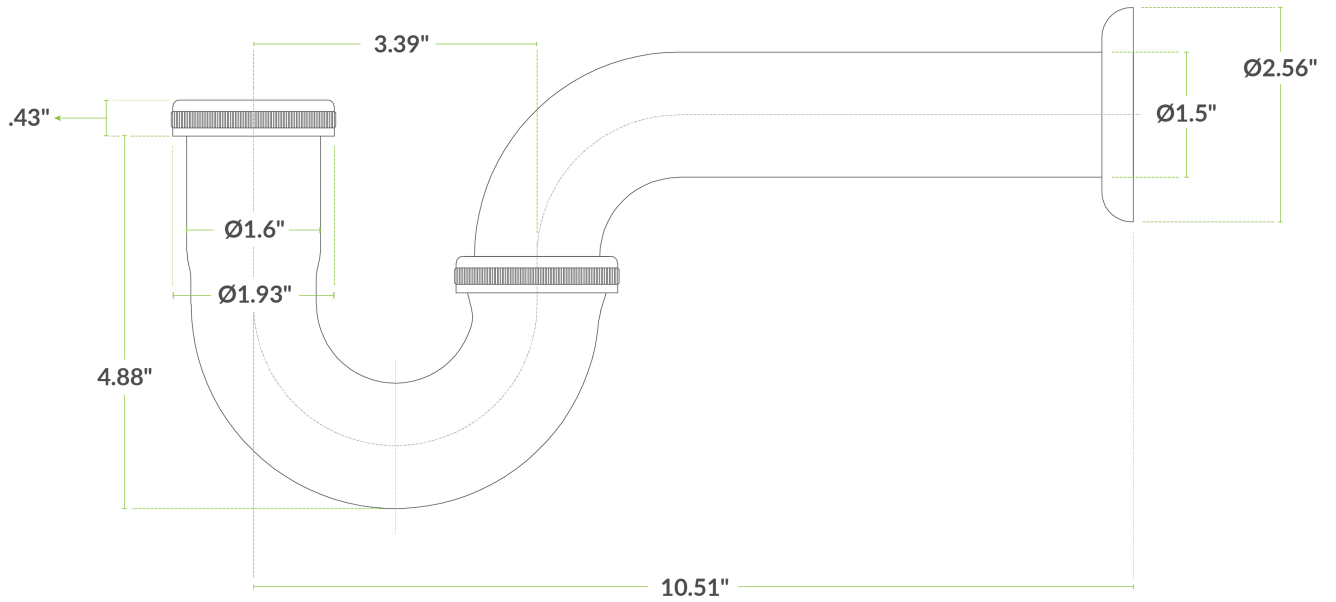
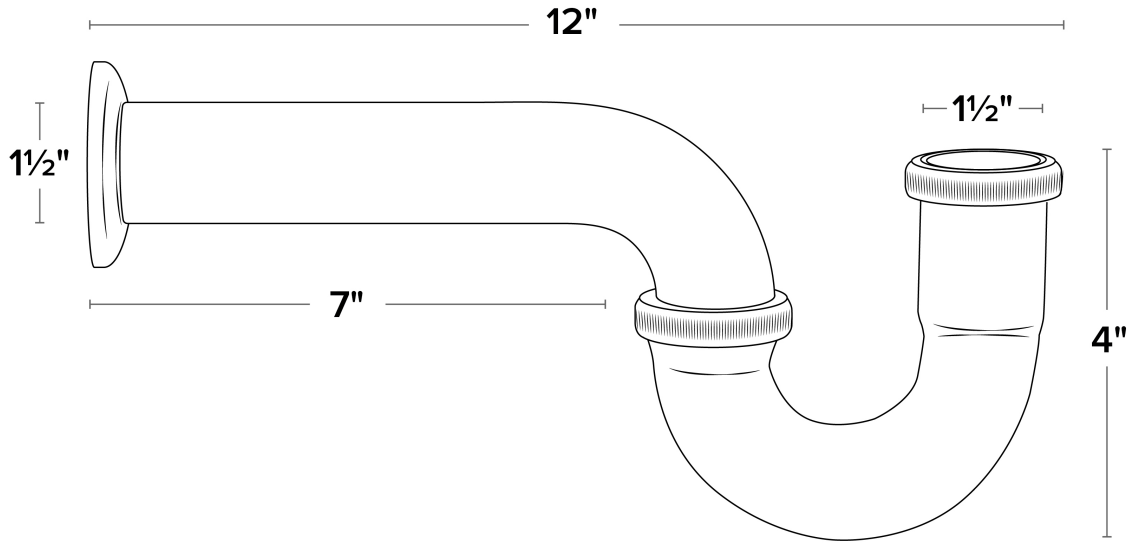

Notes & Details

Prevent unpleasant sewage odors and gases from escaping your drain pipe with this Regency PTRAP chrome P-trap! Thanks to a purposeful curved design, water is trapped in the "U" shaped pipe, which then acts as a barrier against the odors and gases that would otherwise drift up and out into the air. If you notice foul odors coming from your sink, check to make sure your P-trap is functioning properly. If it isn't, use this replacement piece to get things working again as soon as possible! This heavy-duty, 22 gauge chrome p-trap has a 1 1/2" IPS drain connection.

**⚠ WARNING:** This product can expose you to chemicals including lead, which are known to the State of California to cause cancer, birth defects, or other reproductive harm. For more information, go to [www.p65warnings.ca.gov](http://www.p65warnings.ca.gov).