



Regency Lever Handle Waste Valve 3 1/2" Sink Opening

#600DL1



Technical Data

Basket Drain Size	3 1/2 Inches
Drain Outlet Size	2 Inches
Features	with ScrapLock
Type	Lever Waste Valves

Features

- 2" NPT drain outlet
- Fits a 3 1/2" sink opening
- Strainer keeps larger waste out of the drain
- Comfortable, easy-to-use lever

Plan View

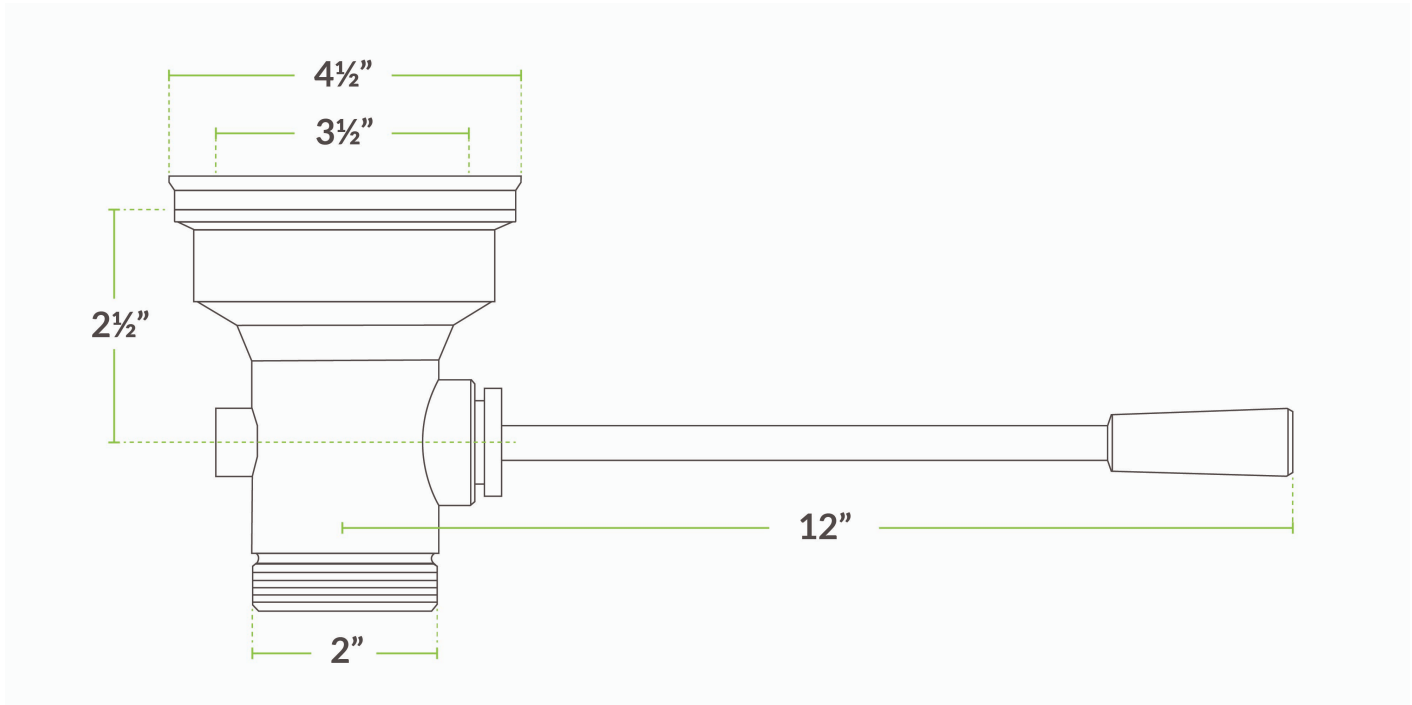

Notes & Details

This lever handle waste valve features a 2" drain outlet that's perfect for any commercial pot sink with a 3 1/2" opening. Easy to install, this waste valve employs its simple design to ensure a tight seal and prevent leaking. Unlike traditional drains that require your staff to reach into dirty wash water for emptying, this unit features a long lever underneath the sink bowl for hassle-free, safe water removal. The lever's rubber handle provides comfort and grip during use.

This lever handle waste valve from Regency is sure to streamline your warewashing and janitorial tasks, and your staff will love its convenient, easy-to-use design. The included strainer drain top prevents larger waste particles from entering your drain in order to keep your pipes flowing smoothly, and it's removable for easy cleaning as needed.

⚠ WARNING: This product can expose you to chemicals including lead, which are known to the State of California to cause cancer, birth defects, or other reproductive harm. For more information, go to www.p65warnings.ca.gov.