

HURRICANE IMPACT WINDOWS

MANUAL, SELF-CLOSING & FULLY AUTOMATIC



SC-4030-IP



STANDARD FEATURES

- Miami Dade County Approved NOA - #25-0401.03
- 3/4" insulated storm glass
- Shipped fully-assembled and ready to install
- Weather resistant and sealed to protect from the elements
- Dark bronze or clear anodized aluminum
- Corrosion resistant material: anodized aluminum and #304-#3 finish stainless steel
- Security locking systems
- Maximum security hook-bolt locks
- Right or left hand units
- Warranty backed with Nationwide Service Centers

OPTIONAL FEATURES

- Custom finish and colors available

MIAMI-DADE COUNTY HURRICANE IMPACT CERTIFIED WINDOWS

Quikserv is proud to produce the largest line of Hurricane Impact transaction windows on the market. These models are self-closing, top hung, single sliders. We make both manual opening and fully automatic versions. These units passed large and small impact testing, as well as water infiltration requirements. This series of single sliders has the same excellent quality you have come to expect from Quikserv sliding windows tested to the most stringent and rigorous testing required for Miami-Dade certification.

Hurricane Impact Rated Automatic Windows

SS-4035E-IP - Unit Size: 48"W x 36"H

SS-4844E-IP - Unit Size: 47-1/2"W x 43-1/2"H

BP-7241E-IP - Unit Size: 72"W x 41"H

Hurricane Impact Rated Self-Closing Windows

SC-4040-IP - Unit Size: 40"W x 40"H

SC-4844-IP - Unit Size: 47-1/2"W x 43-1/2"H

SC-4030-IP - Unit Size: 48"W x 36"H

SC-3030-IP - Unit Size: 36"W x 36"H

MAXIMUM SECURITY
LOCKING SYSTEM



THRU-BEAM PHOTO-ELECTRIC EYE-BAR

MAXIMUM SECURITY SELF-LATCHING HANDLE & LOCKING SYSTEM

Each Quikserv single-sliding manual window model offers our own oversized and easy to operate, self-latching handle for simple and intuitive operation of the window. They also feature an industry proven, Adams Rite thumbturn lock for enhanced security and protection of the building.

THRU-BEAM PHOTO ELECTRIC EYE-BAR FOR AUTOMATIC WINDOWS

Activated when the attendant stands between the emitter and the receiver. Available on all electric sliders and is best used for high volume stores where quick and seamless transactions with customers are essential.



MODEL SS-4035E-IP

ROUGH OPENING: 48-3/8"W x 41-3/8"H
SERVICE OPENING: 20"W X 27" H

MAIN VIEW

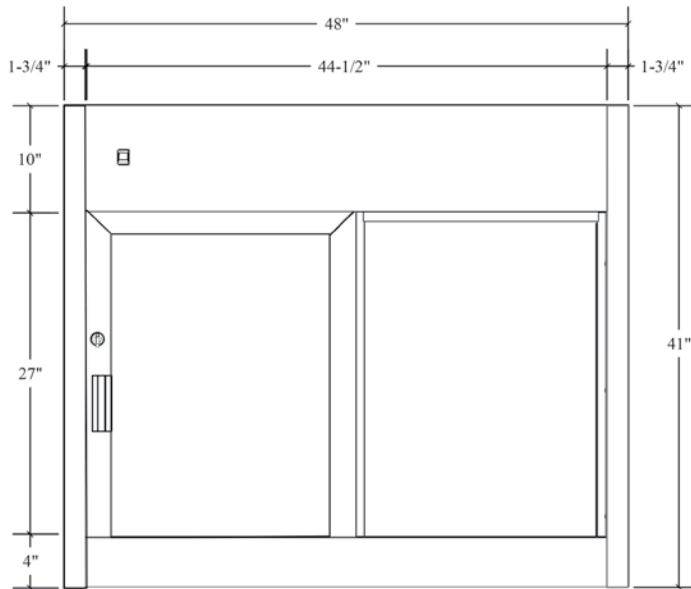

MODEL IFSC-4040-IP

ROUGH OPENING: 48-3/8"W x 48-3/8"H
SERVICE OPENING: 19-1/4"W x 39"H

MAIN VIEW

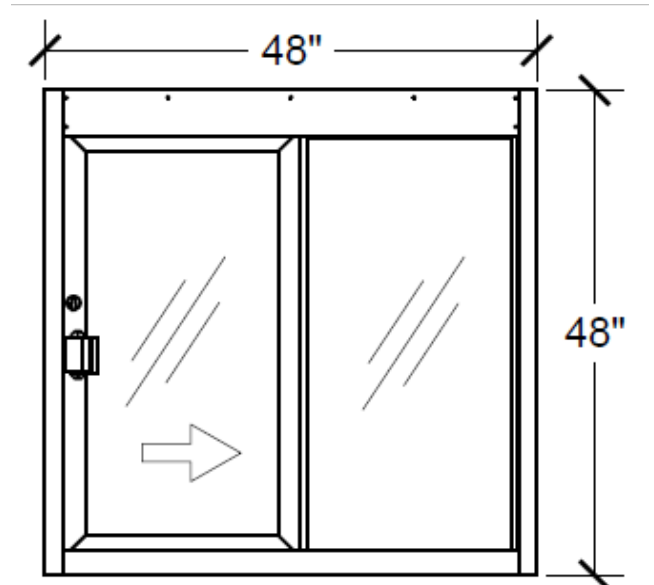

MODEL SC-4030-IP

ROUGH OPENING: 48-3/8"W x 36-3/8"H
SERVICE OPENING: 19-1/4"W x 27"H

MAIN VIEW

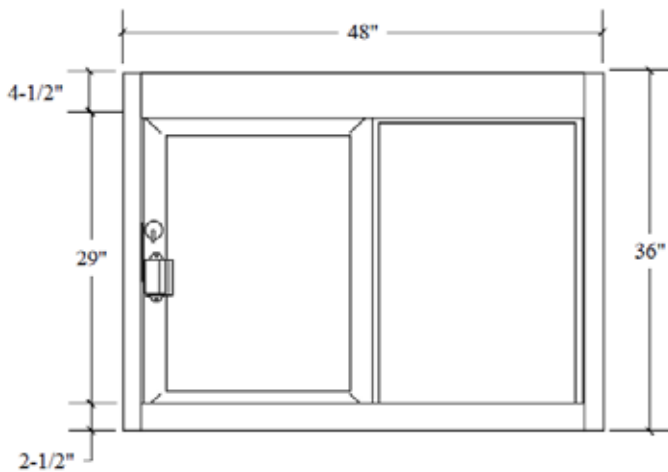

MODEL SC-3030-IP

ROUGH OPENING: 36-3/8"W x 36-3/8"H
SERVICE OPENING: 13-1/2"W X 27"H

MAIN VIEW

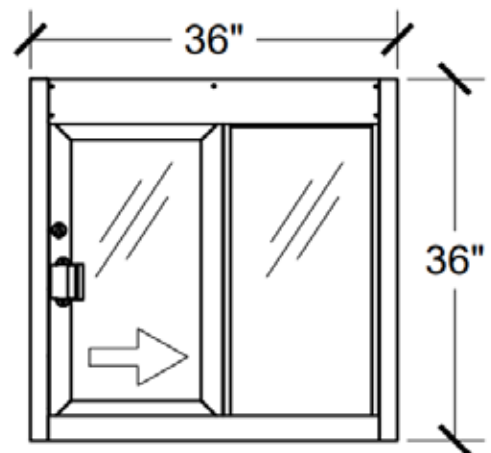

ALL QUIKSERV PRODUCTS ARE SHIPPED FULLY-ASSEMBLED and READY TO INSTALL. EACH ELECTRICAL UNIT IS SHIPPED WITH A FOUR FOOT (4') BX DROP.