

STEEL PAIL WITH STEEL HANDLE - PAIL-STL-RI

APPROX WEIGHT: 5.32 lbs.
DOES NOT INCLUDE WEIGHT OF POWER OR PACKAGING!!!

ANY ADDITIONS, DELETIONS, OR OMISSIONS MUST BE CORRECTED ON THIS DRAWING AS THIS DRAWING WILL BE CONSIDERED ALL INCLUSIVE

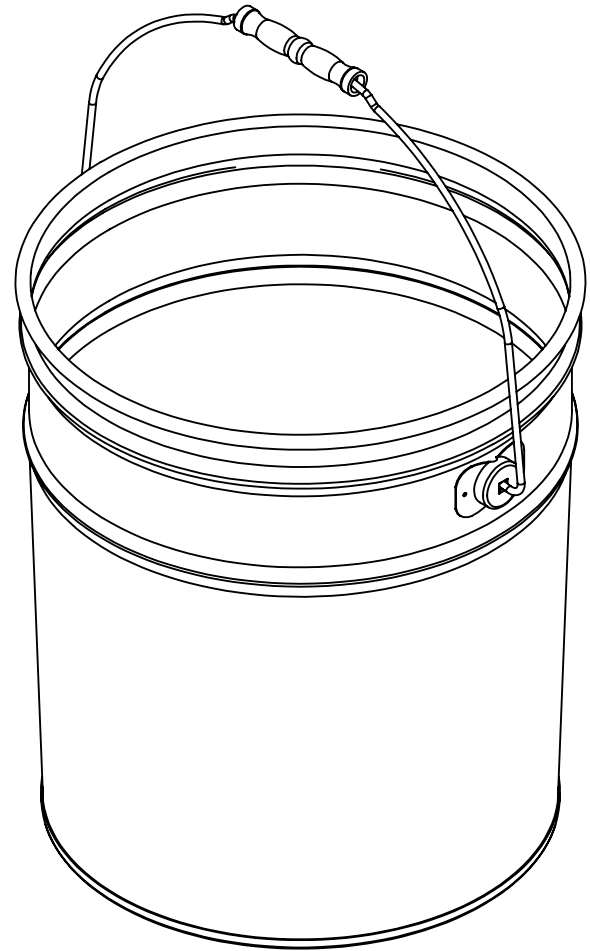
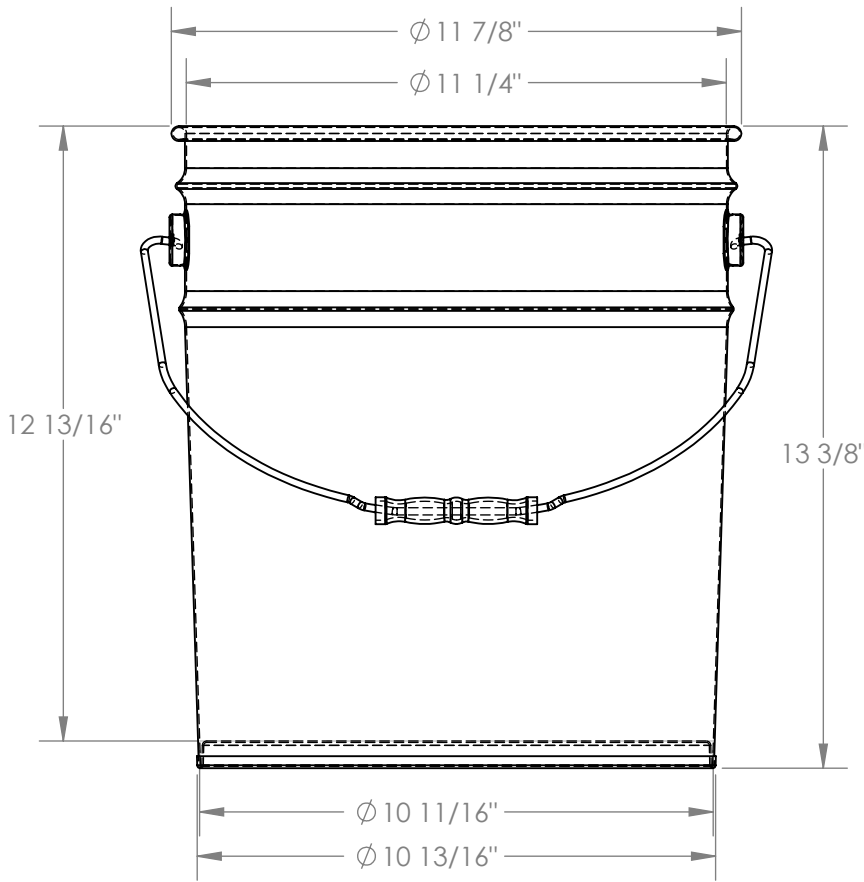

**** NOTE: LID SOLD SEPERATELY ****

DIMENSION TOLERANCE $\pm 1/2"$

ALL GRAPHICS PROVIDED ARE FOR REFERENCE ONLY. IF CERTAIN DIMENSIONS ARE CRITICAL PLEASE VERIFY THOSE DIMENSIONS WITH YOUR SALESPERSON

STANDARD FEATURES

- MODEL NUMBER IS PAIL-STL-RI
- CAPACITY IS: 5 GALLONS
- OUTER TOP DIAMETER IS: $\phi 11 7/8"$
- INNER TOP DIAMETER IS: $\phi 11 1/4"$
- OUTER BOTTOM DIAMETER IS: $\phi 10 13/16"$
- INNER BOTTOM DIAMETER IS: $\phi 10 11/16"$
- OVERALL HEIGHT IS: $13 3/8"$
- INNER HEIGHT IS: $12 13/16"$
- MATERIAL IS: STEEL
- COLOR IS: BLACK
- MINIMUM WALL THICKNESS IS: 29 GA
- PAIL INTERIOR COATED W/RUST INHIBITED COATING
- BAKED ROLLER COAT OF ENAMEL ON BODY AND TOP
- RUST PROOF COATING IS GOOD TO 190 DEGREES

SPECIAL FEATURES

NONE

| FOR INTERNAL USE ONLY PROJECT SIGN OFF | |
|---|--|
| SALES | |
| ENG. | |
| FAB. | |
| POWER | |

| | | |
|---|--|--|
| A P P R O V A L | I, THE UNDERSIGNED, AGREE THAT THE PRODUCT AS REPRESENTED SATISFIES DESIGN AND DIMENSION REQUIREMENTS. I ALSO ACKNOWLEDGE MY DUTY TO CONFIRM PRODUCT AND INSTALLATION COMPLIANCE WITH ALL APPLICABLE FEDERAL, STATE AND LOCAL REGULATIONS AND STANDARDS. | |
| | ANY MODIFIED UNITS ARE NON-RETURNABLE | |
| | [] As drawn [] As marked | |
| | Signed: _____ Date: _____ | |
| Printed Name: _____ | | |
| LEAD TIME WILL START UPON RECEIPT OF SIGNED APPROVAL DRAWING | | |

| | | |
|-----------------------------|------------|-------------|
| DISTRIBUTOR'S NAME: | | P.O.# |
| VESTIL MANUFACTURING | | X |
| | | W.O.# |
| DRAWN BY: TJM | | X |
| DATE: 04/02/12 | | SALES: X |
| REFERENCE: X | SCALE: 1:4 | FILE NAME: |
| QUOTED LEAD TIME: X | QUOTE # | 30-007-1064 |
| | X | |