



Project \_\_\_\_\_

Item 541E36G24L Quantity \_\_\_\_\_

Approval \_\_\_\_\_ Date \_\_\_\_\_

# Main Street Equipment E36-G24-L Liquid Propane 2 Burner 36" Range with 24" Griddle and Standard Oven - 130,000 BTU

Item #541E36G24L

## Special Features

- Powerful (2) 30,000 BTU open top burners
- Durable aluminum and stainless steel construction
- Includes a 9 3/4" deep back shelf for storage and 2" front ledge for extra workspace
- Lift-off cast iron grates and deep crumb tray for easy cleaning; liquid propane
- 3/4" thick manual steel griddle with (2) 20,000 BTU burners and side splashes

## Technical Data

<b>Width</b>	36 Inches
<b>Depth</b>	32 5/8 Inches
<b>Height</b>	60 3/8 Inches
<b>Griddle Width</b>	24 Inches
<b>Interior Width</b>	26 7/8 Inches
<b>Nominal Width</b>	36 Inches
<b>Interior Depth</b>	25 7/8 Inches
<b>Interior Height</b>	13 7/8 Inches
<b>Burner BTU</b>	30000 BTU
<b>Gas Connection Size</b>	3/4 Inches



## Certifications



ETL Sanitation



3/4" Gas Connection

## Technical Data

<b>Griddle BTU</b>	20000
<b>Installation Type</b>	Freestanding
<b>Number of Burners</b>	2 Burners
<b>Number of Ovens</b>	1 Ovens
<b>Number of Racks</b>	2 Racks
<b>Oven BTU</b>	30000 BTU
<b>Power Type</b>	Liquid Propane
<b>Range Base Style</b>	Standard Oven
<b>Style</b>	Standard
<b>Temperature Range</b>	250 - 550 Degrees F
<b>Top Configuration</b>	Burners with Right Griddle
<b>Total BTU</b>	130000 BTU

## Technical Drawing

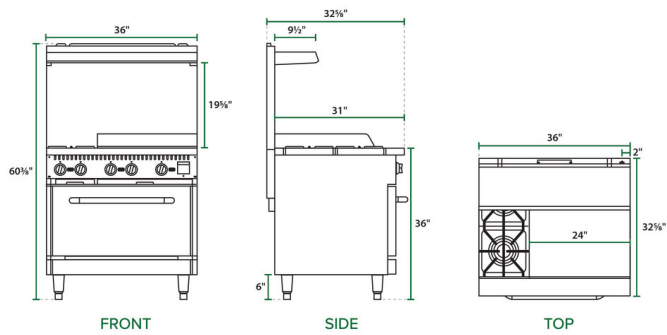

**⚠ WARNING:** This product can expose you to chemicals including lead, which are known to the State of California to cause cancer and birth defects or other reproductive harm. For more information, go to [www.p65warnings.ca.gov](http://www.p65warnings.ca.gov).