

Lancaster Table & Seating Black Steel Bolt-Down Umbrella Base

#427BASEBLTDN



Features

- Durable steel construction
- Includes all installation hardware
- Bolts down for ensured stability
- Great for patios and outdoor dining
- Can be surface mounted onto concrete

Item #: 427BASEBLTDN Qty: _____

Project: _____

Approval: _____ Date: _____

Technical Data

Length	6 1/4 Inches
Width	6 1/4 Inches
Height	14 3/4 Inches
Compatible Pole Diameter	1 1/2 Inches
Assembled	Assembly Required
Color	Black
Material	Steel
Shape	Square
Type	Bases

Plan View

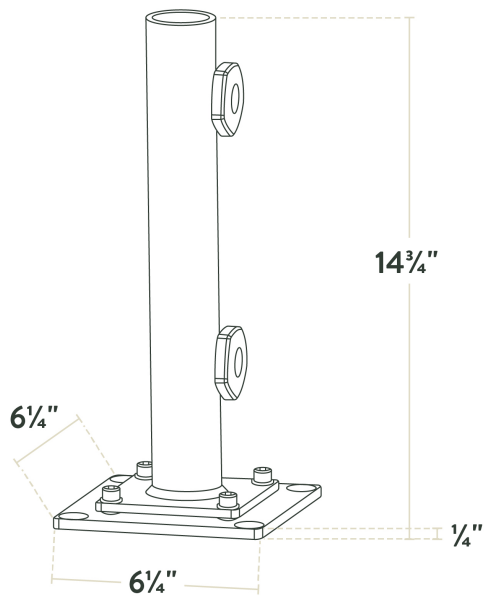

#427BASEBLTDN

Notes & Details

Keep your umbrella secure with this Lancaster Table & Seating black steel bolt-down umbrella base! This base is perfect for use on permanent outdoor patios and dining spaces to ensure your umbrella remains firmly in place. With a durable steel construction, it is built to last and is great for high traffic areas.

This unit is compatible with 1 1/2" diameter umbrella poles. Plus, it includes all necessary hardware so you can install it right away! It also features two knobs that can be tightened to hold your umbrella tightly in place within the base. This durable base is sure to keep your umbrella stable and upright, protecting it from damage and ensuring an excellent outdoor experience for your guests.

Kit Includes:

- Umbrella base
- (4) Nuts
- (8) Washers
- (12) Bolts

⚠ WARNING: This product can expose you to chemicals including lead, which are known to the State of California to cause cancer, birth defects, or other reproductive harm. For more information, go to www.p65warnings.ca.gov.