



Lancaster Table & Seating Black Vinyl Double Ring Swivel Bar Stool

#164GS605BBLK

Item #: 164GS605BBLK Qty: _____

Project: _____

Approval: _____ Date: _____



Features

- Durable steel frame with stylish chrome finish
- Double ring base provides exceptional comfort and support
- Plastic glides protect floors from scratches and scuffs
- 3 1/2" thick black vinyl padded cushion is easy to clean
- Swivel design allows guests to easily socialize

Technical Data

Width	16 Inches
Depth	16 Inches
Height	29 Inches
Height Style	Bar Height
Seat Diameter	14 Inches
Arms	Without Arms
Assembled	Assembly Required
Back	Without Back
Capacity	330 lb.
Color	Silver

Technical Data

Cushion Thickness	3 1/2 Inches
Features	Footrest Swivel Seat
Frame Material	Metal Steel
Padded Seat	With Padded Seat
Seat Color	Black
Seat Material	Vinyl
Seat Type	Solid
Style	Backless
Type	Stools
Usage	Indoor

Plan View

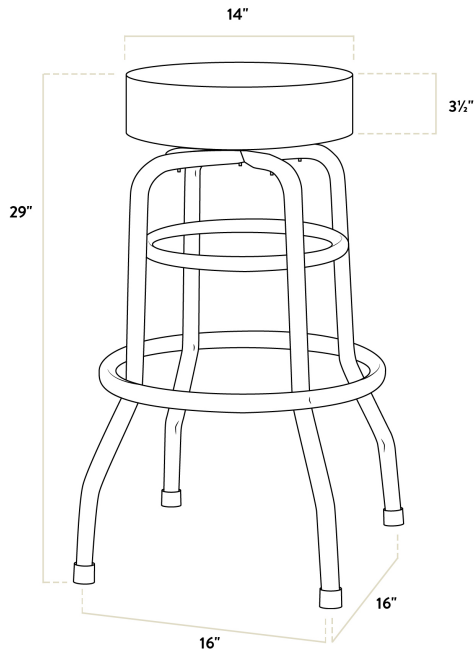

Notes & Details

Seat your guests in comfort and style with this Lancaster Table & Seating black vinyl double ring swivel bar stool. This bar stool's sleek steel frame combines with its stylish chrome finish to instill a classic, timeless look in any location. This stool is perfect for both bar and raised table seating and will provide unmatched comfort while maintaining a distinct appearance. Its reliable design ensures you'll be using this barstool in your retro diner, trendy bar, or game room for years to come.

Thanks to the sturdy steel frame, this bar stool can hold up to 330 lb. of weight. Additionally, the chrome finish on this bar stool ensures longevity through everyday wear and tear, resisting stains, scratches, and smudges. It also features a double ring design for added strength and structural integrity. The 3 1/2" thick black vinyl padded seat provides exceptional comfort for your guests, and it's also durable and easy to clean! Simply use a damp cloth with mild soap to remove any dirt or spills. It is made with fire-retardant foam for added safety.

This bar stool's swivel design allows guests to turn their seats to comfortably socialize and fully enjoy your venue. The double ring base even provides your patrons with a comfortable place to rest their feet while they're drinking your signature cocktails. Each leg comes with an integrated glide to protect your floors from scuffing.

This convenient bar stool weighs less than 15 lb., which makes it easy to rearrange for staff and customers. To save you money, these bar stools are shipped with the seat detached. It comes with all the hardware you need plus an allen wrench to quickly and easily put it together once it arrives.

 **WARNING:** This product can expose you to chemicals including lead, which are known to the State of California to cause cancer, birth defects, or other reproductive harm. For more information, go to www.p65warnings.ca.gov.