



Lancaster Table & Seating Alloy Series Copper Outdoor Cafe Chair

#164CMCAFECPR

Item #: 164CMCAFECPR Qty: _____

Project: _____

Approval: _____ Date: _____



Features

- Rust-resistant steel construction with e-coat sealant and copper powder coat
- Ample 400 lb. weight capacity
- Reinforced frame with under-seat cross bracing enhances strength and stability
- Designed for use indoors and outdoors
- Stackable with other Lancaster Table & Seating Alloy cafe chairs for space-saving storage

Certifications



Stackable



Fully Assembled

Technical Data

Width	17 1/2 Inches
Depth	17 1/2 Inches
Height	33 1/8 Inches
Seat Width	14 Inches
Seat Depth	14 Inches
Back Height	17 Inches
Height Style	Standard Height
Seat Height	17 3/4 Inches
Arms	Without Arms
Assembled	Fully Assembled

Technical Data

Back	With Back
Back Color	Copper
Back Material	Metal
Capacity	400 lb.
Features	E-Coat Sealant Powder Coated Stackable
Finish	E-Coated Powder-Coated
Frame Color	Copper
Frame Material	Metal Steel
Installation Type	Freestanding
Padded Seat	Without Padded Seat
Seat Color	Copper
Seat Material	Metal Steel
Seat Type	Drain Hole
Style	Cafe and Side Chairs Side Chair
Type	Chairs
Usage	Indoor Outdoor

Plan View

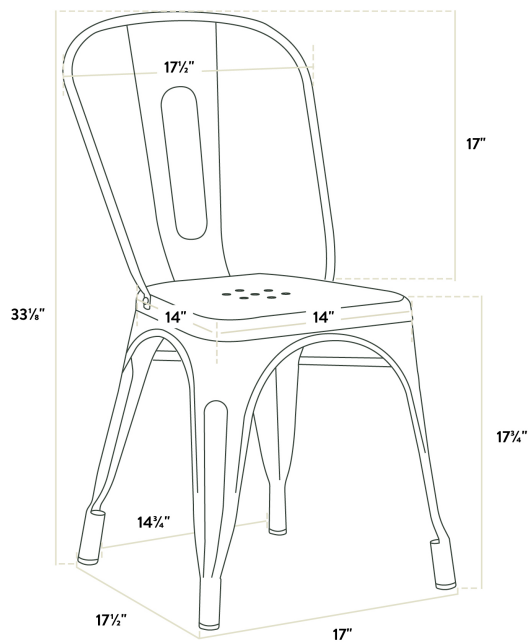

Notes & Details

Take your modern restaurant, cafe, or bistro to the next level with this Lancaster Table & Seating Alloy Series copper outdoor cafe chair! This chair is made of durable steel and double coated to withstand years of use. The copper color adds a sleek, modern touch to any setting and is sure to be a contemporary design choice that guests love. Comfortable and stylish, this strong yet lightweight chair is an excellent choice for your indoor or outdoor dining area. To save time and hassle, this chair ships fully assembled.

Ready to withstand daily outdoor use, this chair is constructed of durable steel. It's then e-coated and powder coated for rust and corrosion resistance as well as extra protection against everyday wear and tear. The frame is reinforced with additional under-seat cross bracing to provide strength and stability without adding extra bulk or weight to this sleek design.

This industrial chair boasts a 400 lb. weight capacity. To ensure that your customers are free to enjoy your signature drinks, appetizers, entrees, and desserts, it features a supportive back and comfortable seat with rounded corners for a sleek, minimalist look. In addition to being stylish and durable, this lightweight chair is also easy to move and transport so you can quickly reconfigure your dining space and easily clean up at the end of the night. It can be used indoors during the off-season then transferred outdoors as the weather gets nicer!

This chair can even be stacked with up to six other Lancaster Table & Seating Alloy Series outdoor cafe chairs to maximize storage space! With a wide variety of color options to choose from, you'll be able to mix and match to create a vibrant seating arrangement in your establishment. This low-maintenance chair features protective glides that help keep floor surfaces in pristine condition. Plus, the drain holes ensure that water won't pool on the seat, helping it to dry faster after washing or accidental spills.

 **WARNING:** This product can expose you to chemicals including lead, which are known to the State of California to cause cancer, birth defects, or other reproductive harm. For more information, go to www.p65warnings.ca.gov.