



## Lancaster Table & Seating Alloy Series Clear Coat Indoor Cafe Chair with Black Fabric Magnetic Cushion

#164CCAFCLRBF

Item #: 164CCAFCLRBF Qty: \_\_\_\_\_

Project: \_\_\_\_\_

Approval: \_\_\_\_\_ Date: \_\_\_\_\_



### Features

- Steel construction dipped in clear coat for a shiny, industrial look
- Ample 400 lb. weight capacity
- Reinforced frame with under-seat cross bracing enhances strength and stability
- Designed for indoor use
- Features comfortable fabric magnetic cushion, back support, and rounded edges

### Certifications



Stackable



Fully Assembled

### Technical Data

Width	17 Inches
Depth	17 1/4 Inches
Height	33 1/2 Inches
Cushion Width	14 1/2 Inches
Seat Width	14 1/8 Inches
Cushion Depth	14 1/4 Inches
Seat Depth	14 1/2 Inches
Back Height	15 3/4 Inches
Height Style	Standard Height
Seat Height	17 3/4 Inches

## Technical Data

Arms	Without Arms
Back	With Back
Back Color	Silver
Back Material	Metal
Capacity	400 lb.
Cushion Thickness	1 1/4 Inches
Features	Magnetic Cushion
Finish	Clear Coat
Frame Color	Silver
Frame Material	Metal Steel
Padded Seat	With Padded Seat
Seat Color	Black
Seat Material	Fabric
Seat Type	Solid
Style	Cafe and Side Chairs Side Chair
Type	Chairs
Usage	Indoor

## Plan View

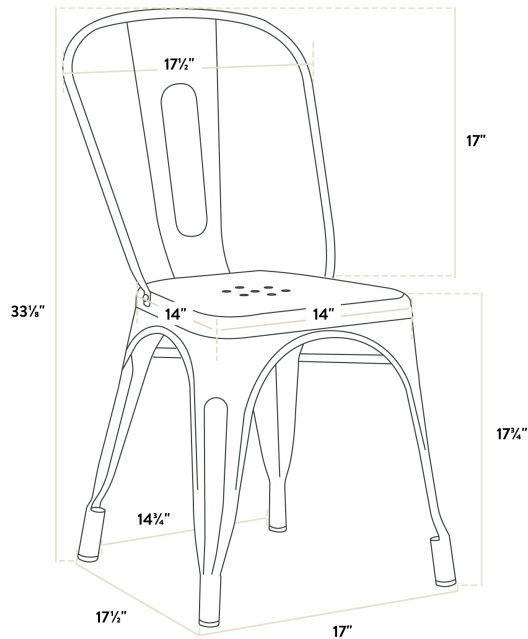

# Notes & Details

---

Take your modern restaurant, cafe, or bistro to the next level with this Lancaster Table & Seating Alloy Series clear coat indoor cafe chair with black fabric magnetic cushion! This chair is made of durable steel to withstand years of use. The sleek clear coat adds a stylish touch to any setting and is sure to be a contemporary design choice that guests love. Comfortable and stylish, this strong yet lightweight chair is an excellent choice for your indoor dining area. To save time and hassle, this chair ships assembled. The cushion ships detached from the chair.

The included black fabric magnetic cushion magnetically connects to the seat and can be easily secured and removed without the need for tools or instructions! Plus, it is water-resistant for added versatility and easy cleanup. Adding a layer of foam between your guests and their seats will amplify their comfort, enticing them to stay longer and enjoy more. Aside from the comfort, this 1 1/4" thick cushion is made with CAL117 fire-retardant foam for added safety.

Ready to withstand daily indoor use, this chair is constructed of durable steel. It also has a clear coat for a shiny, industrial look. The frame is reinforced with additional under-seat cross bracing to provide strength and stability without adding extra bulk or weight to this sleek design. This industrial chair boasts a 400 lb. weight capacity. To ensure that your customers are free to enjoy your signature drinks, appetizers, entrees, and desserts, it features a supportive back and comfortable seat with rounded corners for a sleek, minimalist look.

In addition to being stylish and durable, this lightweight chair is also easy to move and transport so you can quickly reconfigure your dining space and easily clean up at the end of the night. When the cushion is removed, this chair can even be stacked with up to six other Lancaster Table & Seating Alloy Series cafe chairs to maximize storage space! With a wide array of color options to choose from, you'll be able to mix and match to create a vibrant seating arrangement in your establishment. This low-maintenance chair features protective glides that help keep floor surfaces in pristine condition. Cushion cleanup is easy since the fabric exterior protects the foam from direct contact with spills and other natural elements. Simply remove the fabric cover and wash to remove blemishes. The cover is even machine washable!

**⚠ WARNING:** This product can expose you to chemicals including lead, which are known to the State of California to cause cancer, birth defects, or other reproductive harm. For more information, go to [www.p65warnings.ca.gov](http://www.p65warnings.ca.gov).