

Lancaster Table & Seating Black Plastic Dual Height Booster Seat with Chair Strap

#164BCDUALSBK

Item #: 164BCDUALSBK Qty: _____

Project: _____

Approval: _____ Date: _____



Features

- Contoured seat promotes comfort
- Textured exterior prevents children from slipping while in the seat
- Includes dual chair straps for enhanced safety
- Dual height design makes the seat suitable for children of varying ages and sizes
- Non-skid pads help to keep the seat securely in place on chairs

Certifications



Stackable



Fully Assembled

Technical Data

Length	11 Inches
Width	12 1/2 Inches
Height	9 Inches
Maximum Depth	11 Inches
Maximum Seat Height	5 Inches
Minimum Seat Height	3 1/2 Inches
Assembled	Fully Assembled
Color	Black
Features	Chair Strap Stackable

Technical Data

Material	Plastic
Style	Single Seat
Type	Booster Seats
Usage	Indoor Outdoor

Plan View

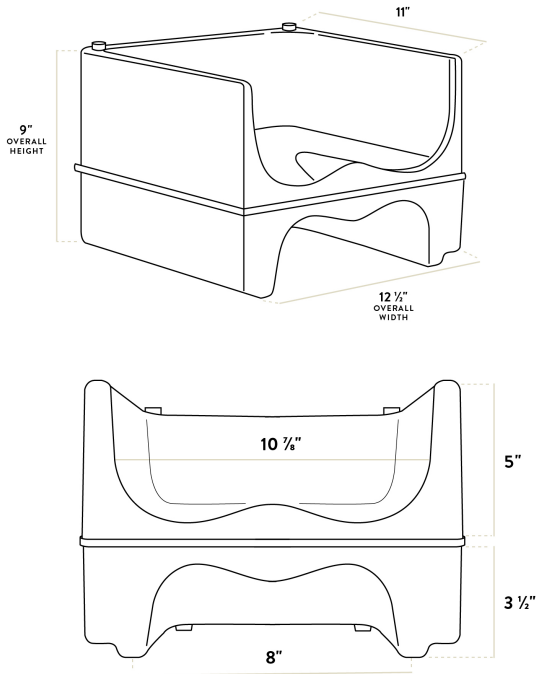

Notes & Details

Give your smallest guests a comfortable place to sit with this Lancaster Table & Seating black plastic dual height booster seat with chair strap! This booster seat features a contoured seat to promote comfort. The textured exterior helps to keep children from slipping around, while the built-in non-skid pads keep the seat securely on chairs. Plus, the dual height design allows you to use the same seat for children of varying ages and sizes. Simply flip the chair to provide a height boost of either 3 1/2 inches or 5 inches.

This booster seat comes with two straps to keep children safe while they're sitting. The first strap attaches to the back of the chair, while the second strap attaches underneath the chair, helping to keep the seat firmly in place. The included snap clasps ensure quick, simple fastening, too.

Made of durable polyethylene plastic with a molded, one-piece construction, this booster seat is made to withstand years of use in your family restaurant, hotel, or daycare facility. Its antimicrobial surface prevents mold and mildew growth for superior sanitation, while its rounded corners make it simple to clean after each guest. The stackable design of these seats allows for easy, space-efficient storage at the end of the day.

This booster seat's wide, square base also provides superior stability. It can be used both indoors and outdoors, but it should be stored indoors when not in use. This booster seat accommodates most children that require a boost at the table. It is only intended for children that can sit up unassisted. Give your young guests the boost they need to easily reach utensils and cups for mess-free meals with this Lancaster Table & Seating dual booster seat!

⚠ WARNING: This product can expose you to chemicals including lead, which are known to the State of California to cause cancer, birth defects, or other reproductive harm. For more information, go to www.p65warnings.ca.gov.