



IP 50 M

Meat mixers - bench / floor



IP 50 M
(shown with optional Set of 4 s/steel legs
w/brake casters)

- 105 lbs. single paddle mixer allow for a fast, homogenous yet gentle mix of a variety of products from sausage meat to potato salad, coleslaw and sandwich fillings - with a great sales appeal and longer shelf-life result
- Complete stainless steel construction
- Forward and reverse mixing action allows for more control over the most delicate products
- Exclusive side opening for easy product discharge from the tub, paddle removal and faster clean-up

Features

Technical

- Completely made from stainless steel.
- Stainless steel paddle rotates for a thorough mixing and a faster kneading.
- The openable side lid facilitates easy product emptying, fast cleaning and maintenance.

Safety

- A safety interlock stops the machine when opening the lid.
- Overload and no volt release protection

Sanitary

- Removable paddle for an easy and accurate cleaning.

Optional

- Set of 4 s/steel legs with brake casters

Specifications

- Motor:** 1.15 Hp (850W), 3.7A, fan cooled.
Electrical: 220-240V AC, 60Hz, 1-Phase, 3.7A
Plug and Cord: Attached, flexible, 4 wire (3PH+1G) SJT 14 AWG, 6'4" long cord. NEMA 6-20 P
Controls: ON/OFF/REV stainless steel keypad, IP 67 waterproof protection. No voltage release

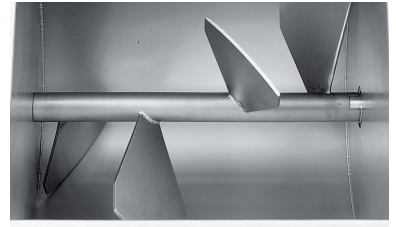

IP 50 M



ON / OFF / REV stainless steel keypad
IP 67 waterproof protection
No voltage release

Easy and fast breakdown for unloading and cleaning

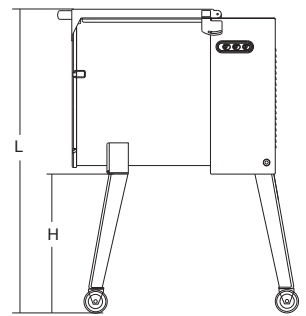
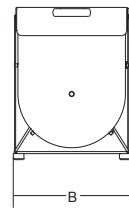
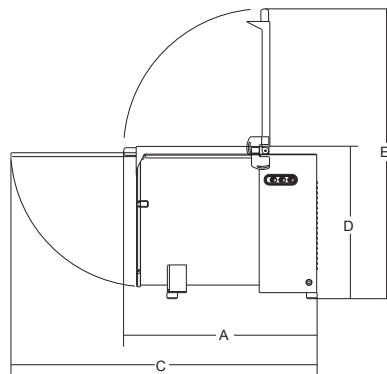

Set of 4 s/steel legs
with brake casters

	Power	Power source	Tank dimensions	Capacity	Tank dimensions						Net weight	Shipping	Gross weight	
	watt/Hp	+/- 10%	inch.	qt	A	B	C	D	E	H				L
IP 50 M	850/1.15	220-240V, 60Hz, 3.7A, 1-ph	16 ^{1/8} " x 18 ^{7/8} "	44,4	29 ^{1/2} "	18 ^{5/16} "	49 ^{3/16} "	23 ^{7/16} "	44 ^{1/8} "	17 ^{5/16} "	39 ^{3/4} "	130	33" x 34" x 33"	163