



**BEVERAGE-AIR®**

PROJECT: \_\_\_\_\_  
 ITEM # \_\_\_\_\_ QTY: \_\_\_\_\_  
 MODEL # \_\_\_\_\_  
 AIA # \_\_\_\_\_ SIS # \_\_\_\_\_  
 APPROVED: \_\_\_\_\_

**HORIZON BOTTOM MOUNT REFRIGERATORS**

**Model: HBR72HC-1-G**

**GLASS DOOR**



**7 YEAR WARRANTY  
 Parts, Labor, and Compressor**

**CABINET CONSTRUCTION**

- Stainless steel front, side, and grille (galvanized back & bottom)
- Stainless steel interior
- Full electronic control with one-touch defrost
- One-piece grille allow easy removal/installation for preventative maintenance
- Self closing door with 120° stay open feature
- LED lighting
- Spring-loaded style hinges
- Plug-in magnetic door gaskets
- Nine (9) heavy duty epoxy coated wire shelves
- 6" Casters with two (2) brakes



**OPTIONS & ACCESSORIES**

- Stainless steel universal tray slide pair, 1 tray slide set for (1) 18" x 26" or (2) 14" x 18" pans (AC)
- 3" Casters or 6" legs
- Wine models
- Door lock
- Epoxy shelves
- Shelf clips
- Remote option\* (see note on back page)

**REFRIGERATION SYSTEM**

- Uses environmentally friendly, energy efficient R290 refrigerant, and meets all regulatory requirements for CARB, SNAP, DOE & more
- Hot gas condensate evaporator
- Adaptive defrost
- Epoxy coated evaporator coil
- Maintains product temperatures between 36°F and 38°F



# BEVERAGE-AIR®

## Horizon Bottom Mount Model: HBR72HC-1-G

PLAN VIEW

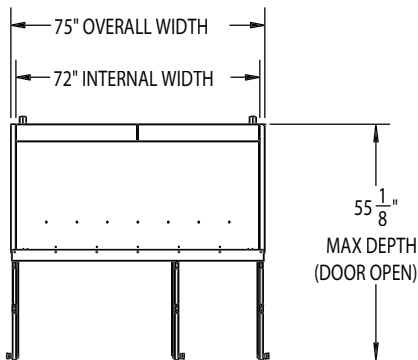

ELEVATION VIEW

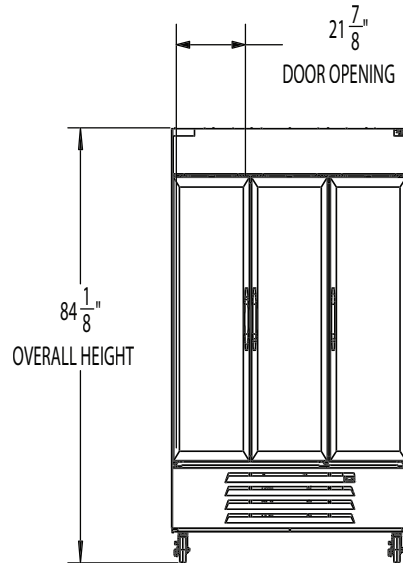

SIDE VIEW

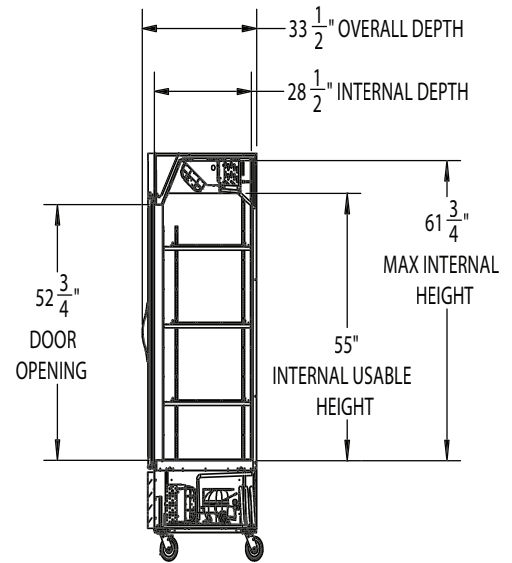

EXTERNAL DIMENSIONAL DATA	
Width Overall (in)	75"
Depth Overall (in)	33 1/2"
Height Overall (in)	84 1/8"
Number of Doors	3
Depth with Door Open 90° (in)	55 1/8"
Door Openings (in)	21 7/8" x 52 3/4"
INTERNAL DIMENSIONAL DATA	
NET Capacity (cubic ft.)	70.19
Internal Width Overall (in)	72"
Internal Depth Overall (in)	28 1/2"
Internal Height Overall (in)	61 3/4"
Number of Shelves	9

\*NOTE: Remote units are field wired and come with 6" legs.  
Refrigerant must be specified at time of order.

We reserve the right to change specifications and product design without notice. Such revisions do not entitle the buyer to corresponding changes, improvements, additions or replacements for previously purchased equipment. Dimensional tolerances +/- 1/4". Metric dimensions (MM).

Required Clearance: Bottom & Rear 3"

ELECTRICAL DATA	
Full Load Amps	6.12
Voltage	115/60/1
Nema Plug (8' cord)	5-15P
REFRIGERATION DATA	
Horsepower	1/2
Capacity (BTU/Hr)	3628
Heat Rejection (BTU/Hr)	5442
Charge (lbs/grams/ounces)	0.2204 / 100 / 3.53
SHIPPING DATA	
Gross Weight - Crated	758 lbs.
Height - Crated (in)	88"
Width - Crated (in)	77"
Depth - Crated (in)	36"

### ELECTRICAL CONNECTION



NEMA 5-15P

115/60/1  
NEMA 5-15P

Unit pre-wired at factory and include 8' long cord and plug set.

3779 Champion Blvd., Winston-Salem, NC 27105 | 888-845-9800 | Fax: 336-245-6453 | Beverage-Air.com | Sales@bevair.com

Date Issued 6/26 | Printed in U.S.A.