



HEATED ZONE MERCHANDISER

Models HZMH-24, -30, -36, -42, -48, -54, -60 HZMH-24D, -30D, -36D, -42D, -48D, -54D, -60D
 HZMS-24, -30, -36, -42, -48, -54, -60 HZMS-24D, -30D, -36D, -42D, -48D, -54D, -60D

ITEM#

The new energy-efficient Hatco Heated Zone Merchandiser safely holds hot packaged food in a smartly designed display that attracts customers. Energy costs are reduced by utilizing Spot On® technology - instant-on overhead elements that are off until a food product is placed on the shelf, compared to other heated merchandisers that stay on full power 100% of the time. Each shelf has multiple heat zones for maximum efficiency. Due to the intensity of the overhead heating elements, Hatco recommends food packaging that can withstand high temperatures.

FLEXIBILITY

This warmer offers the convenience of self-serve and the efficiency of kitchen-to-server holding.

Available in slant or horizontal shelves, the Heated Zone Merchandising Warmers are offered in both single and dual shelf models. Choose from seven *Designer* colors, (black is standard) to blend the Zone Merchandiser with any décor. Non-standard colors are non-returnable

QUALITY

The following features assure the finest performance for years to come:

- New Spot On technology turns overhead heat on only when product is present in that zone. Base heat goes from energy saving mode to the temperature you can set
- Fast action ribbon elements will be up to temperature in less than 10 seconds
- Choose from slant or horizontal shelves, single or dual shelf models, and in 2 to 12 zones, depending on the model size
- LCD display scans and displays the various zone settings
- Hinged glass side panels swing out for easy cleaning
- Channel dividers are held in place by magnets, giving the unit more heated surface

Heated Zone Merchandiser with Spot-ON® technology

Equipment On Signage Program
 Hatcographics.com



Model HZMS-36D with optional LED accent lighting in support posts

Model Width	Total Zone Space x 21.75"D (552 mm)	Divider Rods Provided	Zone Width	Zones per Shelf
24	20.08"W (510 mm)	3 Rods per Shelf	20.08"W (510 mm)	2
30	24.78"W (629 mm)	4 Rods per Shelf	12.39"W (315 mm)	4
36	30.74"W (780 mm)	4 Rods per Shelf	15.37"W (390 mm)	4
42	36.74"W (933 mm)	6 Rods per Shelf	18.37"W (467 mm)	4
48	42.74"W (1085 mm)	6 Rods per Shelf	21.37"W (543 mm)	4
54	47.52"W (1207 mm)	6 Rods per Shelf	15.84"W (402 mm)	6
60	53.52"W (1359 mm)	9 Rods per Shelf	17.84"W (453 mm)	6

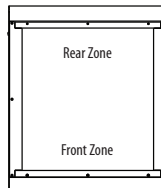

HZM-24

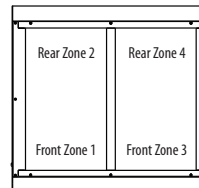

HZM-30

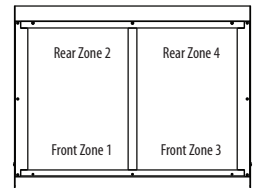

HZM-36

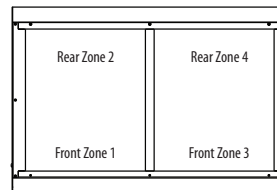

HZM-42

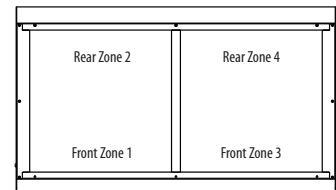

HZM-48

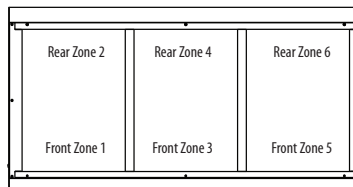

HZM-54

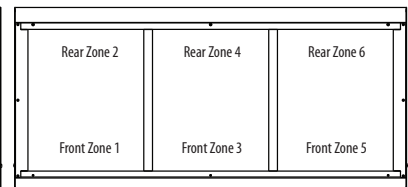

HZM-60



HEATING ELEMENTS GUARANTEED AGAINST BURNOUT AND BREAKAGE FOR ONE YEAR.



HATCO CORPORATION P.O. Box 340500 Milwaukee, WI 53234-0500 U.S.A.
 (800) 558-0607 • (414) 671-6350 • Fax (800) 543-7521 • Int'l. Fax (414) 671-3976
 www.hatcocorp.com • E-mail: equipsales@hatcocorp.com

Form No. HZM Spec Sheet

Printed in U.S.A.
 October 2012



HEATED ZONE MERCHANDISER

Models HZMH-24, -30, -36, -42, -48, -54, -60 HZMH-24D, -30D, -36D, -42D, -48D, -54D, -60D
 HZMS-24, -30, -36, -42, -48, -54, -60 HZMS-24D, -30D, -36D, -42D, -48D, -54D, -60D

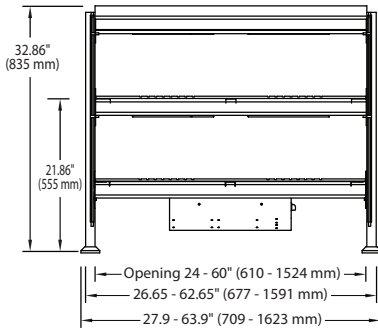

FRONT VIEW
Horizontal

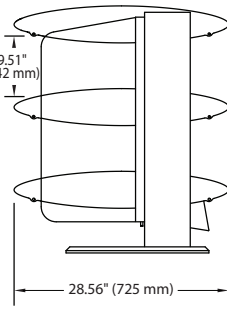

SIDE VIEW
Horizontal

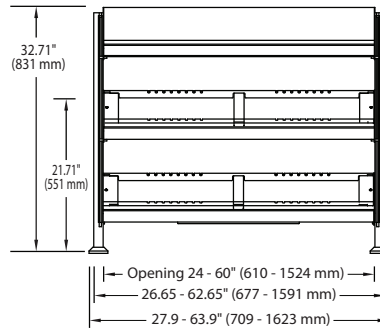

FRONT VIEW
Slant

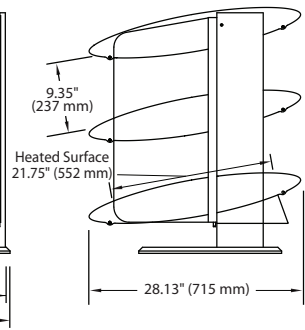

SIDE VIEW
Slant

SPECIFICATIONS

Horizontal Models

	Model	Voltage	Watts	Amps	No. of Heat Zones
Single Shelf	HZMH-24	120	750	6.3	2
	HZMH-30	120	1350	11.3	4
	HZMH-36	120	1400	11.7	4
	HZMH-42	120	1450	12.1	4
	HZMH-48	120	1500	12.5	4
	HZMH-54	120	2100	17.5	6
	HZMH-60	120	2150	17.9	6
Dual Shelf	HZMH-24D	120	1500	12.5	4
	HZMH-30D	120/208-240	2700	11.3	8
	HZMH-36D	120/208-240	2800	11.7	8
	HZMH-42D	120/208-240	2900	12.1	8
	HZMH-48D	120/208-240	3000	12.6	8
	HZMH-54D	120/208-240	4200	17.6	12
HZMH-60D	120/208-240	4300	18.0	12	

Slant Models

	Model	Voltage	Watts	Amps	No. of Heat Zones
Single Shelf	HZMS-24	120	750	6.3	2
	HZMS-30	120	1350	11.3	4
	HZMS-36	120	1400	11.7	4
	HZMS-42	120	1450	12.1	4
	HZMS-48	120	1500	12.5	4
	HZMS-54	120	2100	17.5	6
Dual Shelf	HZMS-24D	120	1500	12.5	4
	HZMS-30D	120/208-240	2700	11.3	8
	HZMS-36D	120/208-240	2800	11.7	8
	HZMS-42D	120/208-240	2900	12.1	8
	HZMS-48D	120/208-240	3000	12.6	8
	HZMS-54D	120/208-240	4200	17.6	12
HZMS-60D	120/208-240	4300	18.0	12	

DIMENSIONS

Horizontal Models (HZMH) –

Single: 27.9" - 63.9"W x 28.56"D x 21.86"H (709-1623 x 725 x 555 mm).

Dual: 27.9" - 63.9"W x 28.56"D x 32.86"H (709-1623 x 725 x 835 mm).

Slant Models (HZMS) –

Single: 27.9" - 63.9"W x 28.13"D x 21.71"H (709-1623 x 715 x 551 mm).

Dual: 27.9" - 63.9"W x 28.13"D x 32.71"H (709-1623 x 715 x 831 mm).

VOLTAGE

HZMH-24 to -36: 120 volts, single phase (use NEMA 5-15P)

HZMH-42 and -48: 120 volts, single phase (use NEMA 5-20P)

HZMH-54 and -60: 120 volts, single phase (use NEMA 5-30P)

HZMH-24D: 120 volts, single phase (use NEMA 5-20P)

HZMH-30D to -48D: 120/208-240 volts, single phase (use NEMA L14-20P)

HZMH-54D to -60D: 120/208-240 volts, single phase (use NEMA L14-30P)

HZMS-24 to -36: 120 volts, single phase (use NEMA 5-15P)

HZMS-42 and -48: 120 volts, single phase (use NEMA 5-20P)

HZMS-54 and -60: 120 volts, single phase (use NEMA 5-30P)

HZMS-24D: 120 volts, single phase (use NEMA 5-20P)

HZMS-30D to -48D: 120/208-240 volts, single phase (use NEMA L14-20P)

HZMS-54D to -60D: 120/208-240 volts, single phase (use NEMA L14-30P)

CORD LOCATION

Back center of base, on left side of control box.-

PLUG CONFIGURATIONS

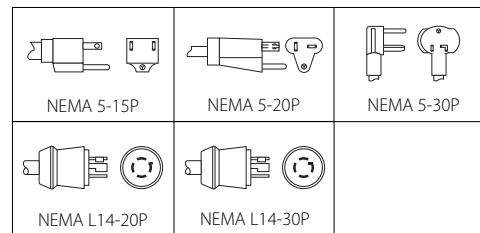

OPTIONS (NOT FOR RETROFIT)

- Designer Colors: Warm Red, Black (standard), Gray Granite, White Granite, Navy Blue, Hunter Green, Antique Copper, non-standard colors are non-returnable
- LED accent lighting in support posts
- Flip-up Doors for front or back (not compatible with optional sneeze guards in same opening)

- Sneeze Guards for front or back (not compatible with optional flip-up doors in same opening)

ACCESSORIES

- Additional Stainless Steel Divider Rods

PRODUCT SPECS

Designer Merchandising Warmer

The Heated Zone Merchandising Warmer shall be model ... as manufactured by the Hatco Corporation, Milwaukee, WI 53234 U.S.A.

The warmer shall be rated at ... watts, ... volts, and be ... inches (millimeters) in overall width. It shall consist of a thermostatically-controlled heated base, infrared

heat from above, full-view tempered glass sides, and LED display lights. The merchandiser shall have fast heating infrared ribbon elements and will have a cord with plug attached.

Accessories shall include additional stainless steel dividers rods.

One year on-site parts and labor warranty, with 24/7 service (U.S. and Canada only).

HATCO CORPORATION P.O. Box 340500 Milwaukee, WI 53234-0500 U.S.A. • (800) 558-0607 • (414) 671-6350
 Fax (800) 543-7521 • Int'l. Fax (414) 671-3976 • www.hatcocorp.com • E-mail: equipsales@hatcocorp.com