



ITEM#

HEATED XENON MERCHANDISER

Models HXMH-24, -30, -36, -42, -48, -54, -60 HXMH-24D, -30D, -36D, -42D, -48D, -54D, -60D
HXMS-24, -30, -36, -42, -48, -54, -60 HXMS-24D, -30D, -36D, -42D, -48D, -54D, -60D

The new Heated Xenon Merchandiser is sleekly designed to safely hold hot packaged food to attract your grab-and-go customers.

FLEXIBILITY

Available in slant or horizontal shelves, the Heated Xenon Merchandising Warmers are offered in both single and dual shelf models. Choose from seven *Designer* colors, (black is standard) to blend into any décor. Non-standard colors are non-returnable.

QUALITY

The following features assure the finest performance for years to come:

- Choose from slant or horizontal shelves, single or dual shelf models
- Infrared heat safely holds hot packaged product for hours
- Xenon lighting creates better illumination of food product in the holding area
- Feature a thermostatically-controlled hardcoated heated base shelf
- Hinged glass side panels are held in place magnetically and swing out for easy cleaning
- An optional Indicating Temperature Control (ITC) enhances accurate control of temperature

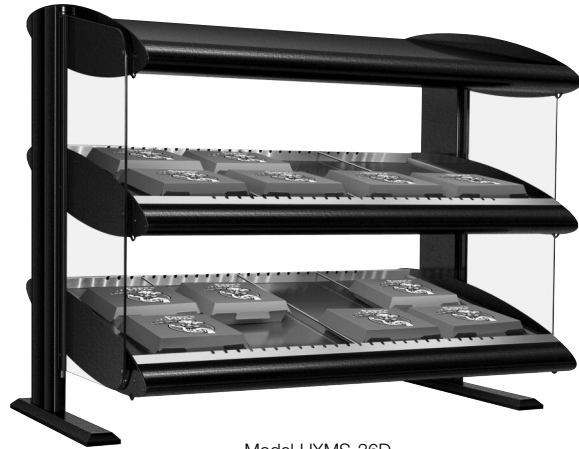

Model HXMS-36D

Model Width	Total Heated Shelf Space x 21.75"D (552 mm)	Divider Rods Provided	Bulbs per Shelf
24	22.34"W (567 mm)	5 Rods per Shelf	2
30	28.34"W (720 mm)	6 Rods per Shelf	2
36	34.34"W (872 mm)	7 Rods per Shelf	3
42	40.34"W (1025 mm)	8 Rods per Shelf	4
48	46.34"W (1177 mm)	9 Rods per Shelf	4
54	52.34"W (1329 mm)	10 Rods per Shelf	4
60	58.34"W (1482 mm)	12 Rods per Shelf	5

HEATING ELEMENTS GUARANTEED AGAINST BURNOUT AND BREAKAGE FOR ONE YEAR.

HATCO CORPORATION P.O. Box 340500 Milwaukee, WI 53234-0500 U.S.A.
(800) 558-0607 • (414) 671-6350 • Fax (800) 543-7521 • Int'l. Fax (414) 671-3976
www.hatcocorp.com • E-mail: equipsales@hatcocorp.com

Form No. HXM Spec Sheet

Printed in U.S.A.
April 2013



HEATED XENON MERCHANDISER

Models HXMH-24, -30, -36, -42, -48, -54, -60 HXMH-24D, -30D, -36D, -42D, -48D, -54D, -60D
HXMS-24, -30, -36, -42, -48, -54, -60 HXMS-24D, -30D, -36D, -42D, -48D, -54D, -60D

ITEM#

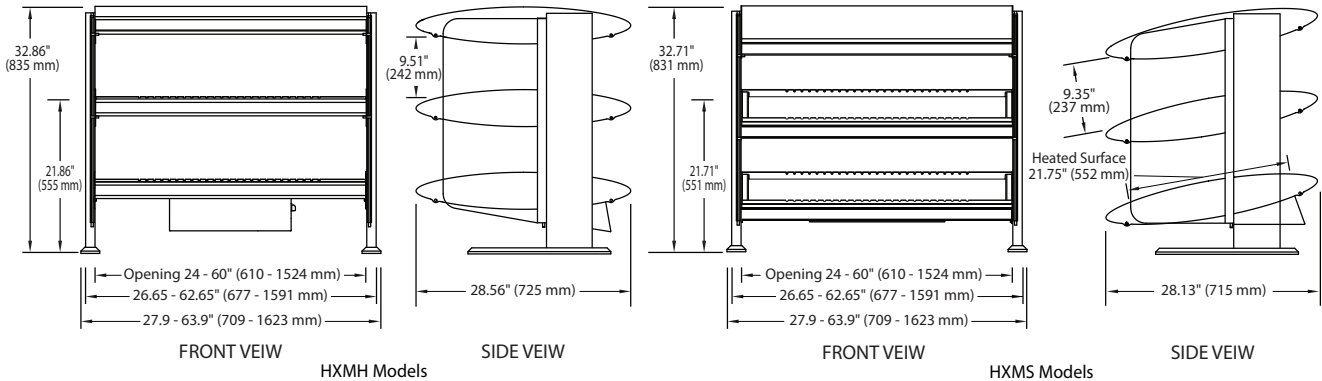

SPECIFICATIONS Horizontal Models

	Model	Voltage	Watts	Amps	Bulbs per Shelf
Single Shelf	HXMH-24	120	800	6.7	2
	HXMH-30	120	1000	8.3	2
	HXMH-36	120	1250	10.4	3
	HXMH-42	120	1400	11.7	4
	HXMH-48	120	1650	13.8	4
	HXMH-54	120	1850	15.4	4
Dual Shelf	HXMH-60	120	2100	17.5	5
	HXMH-24D	120	1600	13.3	2
	HXMH-30D	120/208-240	2000	8.3	2
	HXMH-36D	120/208-240	2500	10.4	3
	HXMH-42D	120/208-240	2800	11.7	4
	HXMH-48D	120/208-240	3300	13.8	4

Slant Models

	Model	Voltage	Watts	Amps	Bulbs per Shelf
Single Shelf	HXMS-24	120	800	6.7	2
	HXMS-30	120	1000	8.3	2
	HXMS-36	120	1250	10.4	3
	HXMS-42	120	1400	11.7	4
	HXMS-48	120	1650	13.8	4
	HXMS-54	120	1850	15.4	4
Dual Shelf	HXMS-60	120	2100	17.5	5
	HXMS-24D	120	1600	13.3	2
	HXMS-30D	120/208-240	2000	8.3	2
	HXMS-36D	120/208-240	2500	10.4	3
	HXMS-42D	120/208-240	2800	11.7	4
	HXMS-48D	120/208-240	3300	13.8	4

DIMENSIONS

Horizontal Models (HXMH) –
Single: 27.9" - 63.9"W x 28.56"D x 21.86"H
(709-1623 x 725 x 555 mm)
Dual: 27.9" - 63.9"W x 28.56"D x 32.86"H
(709-1623 x 725 x 835 mm)
Slant Models (HXMS) –
Single: 27.9" - 63.9"W x 28.13"D x 21.71"H
(709-1623 x 715 x 551 mm)
Dual: 27.9" - 63.9"W x 28.13"D x 32.71"H
(709-1623 x 715 x 831 mm)

VOLTAGE

HXMH-24 to -42: 120 volts, single phase (use NEMA 5-15P)
HXMH-48 to -54: 120 volts, single phase (use NEMA 5-20P)
HXMH-60: 120 volts, single phase (use NEMA 5-30P)
HXMH-24D: 120 volts, single phase (use NEMA 5-20P)
HXMH-30D to -54D: 120/208-240 volts, single phase
(use NEMA L14-20P)
HXMH-60D: 120/208-240 volts, single phase
(use NEMA L14-30P)

HXMS-24 to -42: 120 volts, single phase (use NEMA 5-15P)
HXMS-48 to -54: 120 volts, single phase (use NEMA 5-20P)
HXMS-60: 120 volts, single phase (use NEMA 5-30P)

HXMS-24D: 120 volts, single phase (use NEMA 5-20P)
HXMS-30D to -54D: 120/208-240 volts, single phase
(use NEMA L14-20P)
HXMS-60D: 120/208-240 volts, single phase
(use NEMA L14-30P)

CORD LOCATION

Back center of base, on left side of control box.

PLUG CONFIGURATIONS

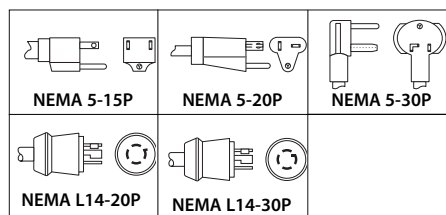

OPTIONS (NOT FOR RETROFIT)

- Designer Colors: Warm Red, Black (standard), Gray Granite, White Granite, Navy Blue, Hunter Green, Antique Copper, non-standard colors are non-returnable
- Red LED accent lighting in support posts
- Indicating Temperature Control (ITC) in lieu of standard mechanical control

- Flip-up Doors for front or back (not compatible with optional sneeze guards in same opening)
- Sneeze Guards for front or back (not compatible with optional flip-up doors in same opening)

ACCESSORIES

- Additional Stainless Steel Divider Rods

PRODUCT SPECS

Designer Merchandising Warmer

The Heated Xenon Merchandising Warmer shall be model ... as manufactured by the Hatco Corporation, Milwaukee, WI 53234 U.S.A.

The warmer shall be rated at ... watts, ... volts, and be ... inches (millimeters) in overall width. It shall consist of a thermostatically-controlled heated base,

infrared heat from above, full-view tempered glass sides, and Xenon display lights. The merchandiser shall have fast heating infrared cal-rod elements and will have a cord with plug attached.

Accessories shall include additional stainless steel dividers rods.

One year on-site parts and labor warranty, with 24/7 service (U.S. and Canada only).

HATCO CORPORATION P.O. Box 340500 Milwaukee, WI 53234-0500 U.S.A. • (800) 558-0607 • (414) 671-6350
Fax (800) 543-7521 • Int'l. Fax (414) 671-3976 • www.hatcocorp.com • E-mail: equipsales@hatcocorp.com