



Project \_\_\_\_\_  
 Item # \_\_\_\_\_  
 Quantity \_\_\_\_\_

## Flav-R-Fresh® Impulse Display Cabinets

Models: FDWD-1, -1X, -2, -2X

The Hatco Flav-R-Fresh® uses controlled moisture and heat to showcase your product longer, not just for minutes but for hours. It holds everything from hot pretzels to 15" (381 mm) pizzas, croissants to bagels, and even hot dogs and meat pies.

Electrical components, controls and water reservoir are located at the top for easy access. Electronic controls monitor cabinet temperature. Models with two doors are available for pass-through convenience and a variety of merchandising racks help enhance food appeal.

The Hatco Flav-R-Fresh is ideal for restaurants, pizzerias, convenience stores, concession stands, snack bars and kiosks.

### Standard features

- Separate heat and humidity controls keep crisp foods crisp and moist foods moist
- The rounded designed cabinet features tempered glass sides and door for full-view display
- Fluorescent light enhances food appeal while safe-guarding food products from bulb breakage
- Single- or double-side opening models
- Doors are reversable (excludes self-closing door)



### Options (available at time of purchase only)

#### Designer Colors

Non-standard colors are non-returnable – Stainless Steel standard

- Warm Red     Black     Gray Granite     White Granite  
 Navy Blue     Hunter Green     Antique Copper

- Self-Closing Door in lieu of standard door. Left hinge only, not field reversible
- 6" Merchandising Display Sign Holder (control side only) (sign not included)
- 3" One Sided Merchandising Display Sign Holder (one per side, three max) (sign not included)
- 6 3/8" One Sided Merchandising Display Sign Holder (one per side, three max) (sign not included)

### Accessories

- 4" (102 mm) Adjustable Legs
- Motorless Rack Coupling (FDWD-1X -2X only)
- 4-tier Circle Rack (Requires coupling for -1X and -2X models)
- 3-shelf Multi-Purpose Rack
- 3-tier Pretzel Tree (Requires coupling for -1X and -2X models)
- 2 Inset Side Panels (*Designer Black* standard)
  - Crescent     Wave
- Curved Headers for Front and Back (*Designer Black* standard)
- Base Skirts (requires 4" [102 mm] adjustable legs, not included) (*Designer Black* standard)
  - Flat front, back and sides     Curved front and back, flat sides

### WATER QUALITY REQUIREMENTS

Incoming water in excess of 3.0 grains of hardness per gallon (GPG) (.75 grains of hardness per liter) must be treated and softened before being supplied to booster heater(s). Water containing over 3.0 GPG (.75 GPL) will decrease the efficiency and reduce the operating life of the unit.

**Note: Product failure caused by liming or sediment buildup is not covered under warranty.**



**HATCO CORPORATION** | P.O. Box 340500 Milwaukee, WI 53234-0500 U.S.A. | (800) 558-0607 | (414) 671-6350  
 Fax: (800) 543-7521 | Int'l. Fax: (414) 671-3976 | www.hatcocorp.com | equipsales@hatcocorp.com | intl@hatcocorp.com



# Flav-R-Fresh® Impulse Display Cabinets

Models: FDWD-1, -1X, -2, -2X

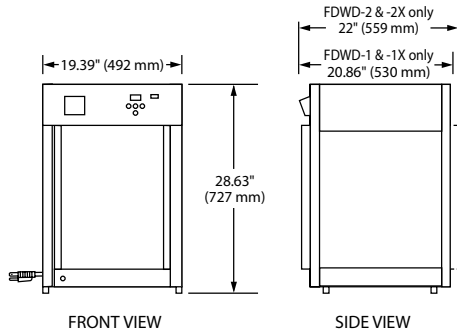

## SPECIFICATIONS Impulse Display Cabinets

The shaded areas contain electrical information for International models

| Model <sup>o</sup> | Type   | Dimensions (W x D x H*)                          | Volts        | Watts     | Amps    | Plug                      | Ship Weight*    |
|--------------------|--|--|--------------|-----------|---------|---------------------------|-----------------|
| FDWD-1             | 1 Door with 4-tier Circle Rack with motor  | 19.39" x 20.86" x 28.63"<br>(492 x 530 x 727 mm) | 100          | 1440      | 14.4    | NEMA 5-15P                | 90 lbs. (41 kg) |
|                    |  |  | 120          | 1390      | 11.6    | NEMA 5-15P                | 90 lbs. (41 kg) |
|                    |  |  | 220          | 1440      | 6.5     | CEE 7/7 Schuko or BS-1363 | 90 lbs. (41 kg) |
|                    |  |  | 240          | 1440      | 6.0     | CEE 7/7 Schuko or AS 3112 |                 |
|                    |  |  | 220-230 (CE) | 1440-1574 | 6.5-6.8 | CEE 7/7 Schuko            |                 |
|                    |  |  | 230-240 (CE) | 1323-1440 | 5.8-6.0 | BS-1363                   |                 |
| FDWD-1X            | 1 Door with 4-shelf Multi-Purpose Rack without motor (not available for retrofit)  | 19.39" x 20.86" x 28.63"<br>(492 x 530 x 727 mm) | 100          | 1440      | 14.4    | NEMA 5-15P                | 90 lbs. (41 kg) |
|                    |  |  | 120          | 1390      | 11.6    | NEMA 5-15P                | 90 lbs. (41 kg) |
|                    |  |  | 220          | 1440      | 6.5     | CEE 7/7 Schuko or BS-1363 | 90 lbs. (41 kg) |
|                    |  |  | 240          | 1440      | 6.0     | CEE 7/7 Schuko or AS 3112 |                 |
|                    |  |  | 220-230 (CE) | 1440-1574 | 6.5-6.8 | CEE 7/7 Schuko            |                 |
|                    |  |  | 230-240 (CE) | 1323-1440 | 5.8-6.0 | BS-1363                   |                 |
| FDWD-2             | 2 Doors with 4-tier Circle Rack with motor   | 19.39" x 22" x 28.63"<br>(492 x 559 x 727 mm)    | 100          | 1440      | 14.4    | NEMA 5-15P                | 90 lbs. (41 kg) |
|                    |  |  | 120          | 1390      | 11.6    | NEMA 5-15P                | 90 lbs. (41 kg) |
|                    |  |  | 220          | 1440      | 6.5     | CEE 7/7 Schuko or BS-1363 | 90 lbs. (41 kg) |
|                    |  |  | 240          | 1440      | 6.0     | CEE 7/7 Schuko or AS 3112 |                 |
|                    |  |  | 220-230 (CE) | 1440-1574 | 6.5-6.8 | CEE 7/7 Schuko            |                 |
|                    |  |  | 230-240 (CE) | 1323-1440 | 5.8-6.0 | BS-1363                   |                 |
| FDWD-2X            | 2 Doors with 4-shelf Multi-Purpose Rack without motor (not available for retrofit) | 19.39" x 22" x 28.63"<br>(492 x 559 x 727 mm)    | 100          | 1440      | 14.4    | NEMA 5-15P                | 90 lbs. (41 kg) |
|                    |  |  | 120          | 1390      | 11.6    | NEMA 5-15P                | 90 lbs. (41 kg) |
|                    |  |  | 220          | 1440      | 6.5     | CEE 7/7 Schuko or BS-1363 | 90 lbs. (41 kg) |
|                    |  |  | 240          | 1440      | 6.0     | CEE 7/7 Schuko or AS 3112 |                 |
|                    |  |  | 220-230 (CE) | 1440-1574 | 6.5-6.8 | CEE 7/7 Schuko            |                 |
|                    |  |  | 230-240 (CE) | 1323-1440 | 5.8-6.0 | BS-1363                   |                 |

<sup>o</sup> Non-humidified cabinets available, unit will only operate in dry mode.

• Height includes standard 1" (25 mm) legs.

\* Shipping weight includes packaging.

### CABINET OPENING

15.75"W x 19.75" H (400 x 502 mm).

### CORD LOCATION

Facing controls, left-hand side panel, lower right corner.

### PRODUCT SPECS

#### Impulse Display Cabinets

The humidity controlled Impulse Display Cabinet shall be a Flav-R-Fresh® Model ... rated at ... volts and ... watts, as manufactured by the Hatco Corporation, Milwaukee, WI 53234 U.S.A.

The cabinet shall have ... door(s), tempered glass sides, stationary rack (or revolving display), and fluorescent display light. It shall include a water reservoir, electronic

### PLUG CONFIGURATIONS

NEMA 5-15P

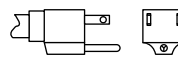

CEE 7/7 Schuko

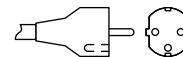

BS-1363

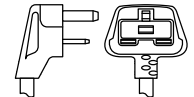

AS 3112

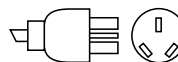

controls, On/Off switch, and indicating lights. A 6' (1829 mm) cord with plug shall be attached.

Accessories shall include merchandising racks, display sign holders (signs not included) and side, top and base skirt.

Warranty consists of 24/7 parts and service assistance (US and Canada only).

**HATCO CORPORATION** | P.O. Box 340500 Milwaukee, WI 53234-0500 U.S.A. | (800) 558-0607 | (414) 671-6350  
 Fax: (800) 543-7521 | Int'l. Fax: (414) 671-3976 | www.hatcocorp.com | equipsales@hatcocorp.com | intl@hatcocorp.com