

Instinct Induction Countertop Single Griddle

Project _____
 Item _____
 Quantity _____
 CSI Section 11400
 Approved _____
 Date _____

Models

- GIIC-SG3.5
- GIIC-SG5.0

powered by
INDUCS



GIIC-SG3.5

Standard Features

- Realtime Temperature Control System (RTCSmp)
- Temperature setting from 50 to 230°C (120 to 450°F)
- Special induction non-stick griddle
- Timer function
- Superior energy-efficiency
- Convenient and reliable
- Short heat-up times
- Overheat protection
- Instantaneous control of the frying temperature with no lag
- Completely uniform heat distribution across the entire cooking surface
- Easy to clean
- LED display
- Includes plug and cord (1.8m/6ft.)
- Simple and intuitive "Tap and Turn" knob

Advanced Features

- RTCSmp control/monitoring
- Height-adjustable, locking feet
- Washable air filter
- Incoming voltage detection
- Easy power reduction
- Quiet ventilation for less noise

Included

- Spatter guard
- Spatula
- Stainless steel pad

Specifications

Significantly reduced energy consumption thanks to high-efficiency induction technology with optimised energy transfer between the griddle and the food product.

Specially developed induction griddle with HPCR stainless steel surface protection.

Contactless multi-point RTCSmp technology for temperature measurement and temperature control accurate to one degree over the entire cooking time and the entire cooking surface for optimal frying results.

Convenient frying without creating ambient heat with direct heat transfer from the griddle to the food product by means of induction.

Especially high operational safety and reliability due to numerous protective features.

Brief heating time under 4-½ minutes.

Easy to clean with removable, washable and reusable air filter.

Exceptionally robust and developed for continuous operation in the restaurant industry.

Reduction of the maximum power from 100% to 25%.

Mains voltage detection and automatic loading of the optimal parameters.

Single-phase version (up to 3.5 kW) at 208 V – 240 V: identical worldwide.

The unit fits the power that the operator has available.

Warranty: 2 years on parts & labor (US and Canada only)

North American models: ETL listed in compliance with, CSA C22.2 No.109, NSF-4 Complies with FCC part 18, ICES-001



Intertek



Intertek





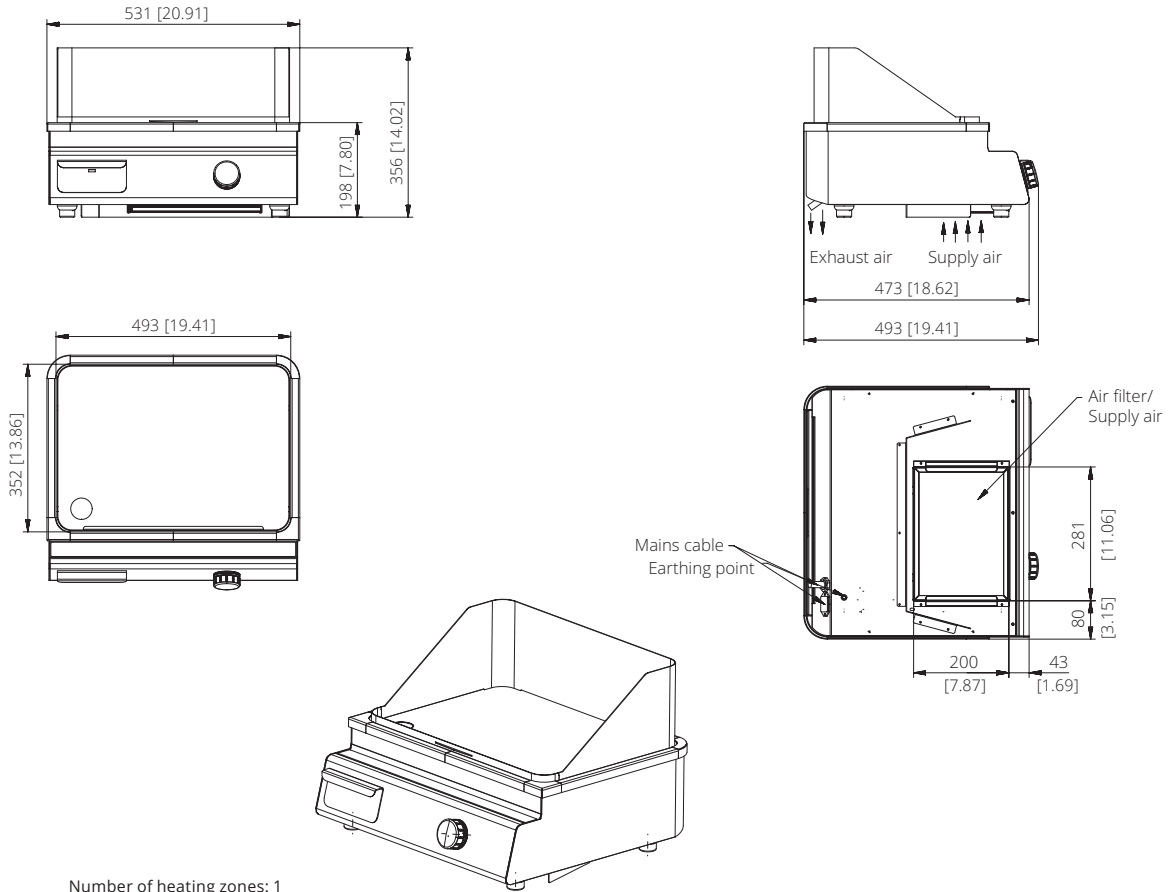

Instinct Induction Countertop Single Griddle

Dimensions are specified in mm [inches]



Number of heating zones: 1
 Griddle surface: 493 x 352 mm [19.41 x 13.86 inches]
 Temperature setting: 50 to 230°C / 120 to 450°F
 Housing: stainless steel

Model	GIIC-SG3.5		GIIC-SG5.0	
Part Number	99650038		99650034	99650035
Dimension W x D x H	531 x 493 x 198 mm [20.91 x 19.41 x 7.80 inches]		531 x 493 x 198 mm [20.91 x 19.41 x 7.80 inches]	
Weight	30 kg [67 lbs]		30 kg [67 lbs]	
Electrical Specifications (EU/US)	Single Phase		3 Phases	
Power, Watts	3500W		5000W	
Electrical supply V/Hz	208-240 V/50-60 Hz/1 16A		208-240 V/50-60 Hz/3 14A	380-440 V/50-60 Hz/3 8A
Plug	 EU1-16P	 NEMA 6-20P	 NEMA L15-20P	 EU 5-Pole
Shipping Information				
Dimensions W x D x H	800 x 600 x 530 mm [31.50 x 23.62 x 20.87 inches]		800 x 600 x 530 mm [31.50 x 23.62 x 20.87 inches]	
Weight	36 kg [79 lbs]		36 kg [79 lbs]	
Cu. Ft.	9		9	

Note:
 Garland products are not approved or authorized for home or residential use, but are intended for commercial applications only.
 Garland will not provide service, warranty, maintenance or support of any kind other than in commercial applications.

Garland reserves the right to make changes to the design or specifications without prior notice.