

## G-Series 36" Gas Restaurant Range with Convection Oven

Project \_\_\_\_\_  
 Item \_\_\_\_\_  
 Quantity \_\_\_\_\_  
 CSI Section 11400  
 Approved \_\_\_\_\_  
 Date \_\_\_\_\_

### Models

- G36-6C
- G36-4G12C
- G36-2G24C
- G36-G36C



Model G36-6C

### Standard Features

- Large 27" (686mm) work top surface
- Stainless steel front and sides
- Stainless steel 5" (127mm) plate rail
- Stainless steel backguard, w/ removable stainless steel shelf
- 12" (305mm) section stamped drip trays w/ dimpled bottom
- 6" (152mm) adj. stainless steel legs
- Large, heavy-duty knobs
- Gas regulator
- Easy to access oven pilot
- Reinforced chassis
- Convection oven w/3 nickel-plated oven racks and removable rack guides w/1/3HP 120v 60 Hz single-phase fan motor
- Snap-action modulating oven thermostat low to 500° F
- Large porcelain oven interior
- Square door design with strong, "keep-cool" oven door handle

#### Standard on Applicable Models:

- Ergonomic split cast-iron top ring grates
- 33,000 BTU/9.67 kW 2-piece cast-iron Starfire® open top burner
- 5/8" (15mm) thick steel griddle plate w/manual hi/lo valve control, 23" (584mm) working depth surface,

Standard on right, optional on left

- Front-serviceable griddle
- 4-1/4" (108mm) wide grease trough
- 18,000 BTU/5.27 kW cast iron "H" style griddle burner per 12" (305mm) width of griddle

### Options & Accessories

- Convection oven motor 240v 50/60HZ single-phase
- Snap-action modulating griddle control 175° to 425° F
- Hot top 12" (305mm) plate in lieu of two open burners, manual valve controlled w/18,000 BTU/5.27 kW cast iron "H" burner standard on left side
- Low-profile 9-3/8" (238mm) backguard stainless steel front and sides
- Additional oven racks
- Four 6" (152mm) levelling swivel casters w/front locking
- Flanged deck mount legs
- Celsius temperature dials
- Piezo spark ignition for pilots on griddles
- Range mount salamanders and cheesemelters are available

### Specifications

Gas restaurant series range with large capacity convection oven.

35 7/16" (900mm) wide, 27" (686mm) deep worktop surfaces.

Stainless steel front, sides and 5" wide front rail.

6" (152mm) legs with adjustable feet.

Six Starfire® 2-piece, 33,000 BTU/9.67 kW (natural gas), cast open burners set in split cast-iron ergonomic grates.

Griddle or optional hot top with cast-iron "H" style burners, 18,000 BTU/5.27 kW (natural gas), in lieu of open burners.

Porcelain oven interior.

Convection oven with 1/3HP 120v 60 Hz single-phase fan motor.

NOTE: Use only Garland certified casters and approved restraining devices.



G-Series 36" Gas Restaurant Range with Convection Oven

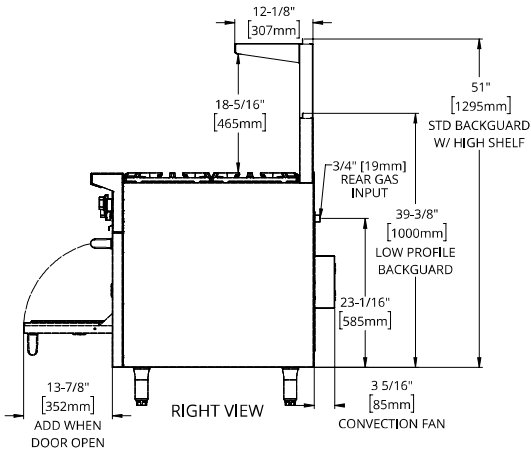
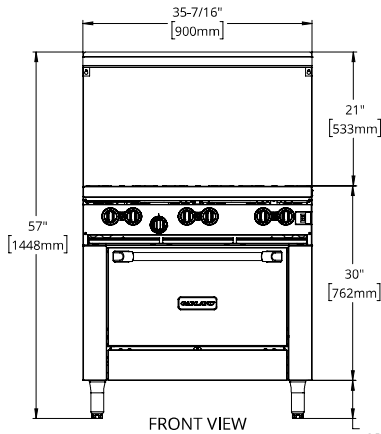
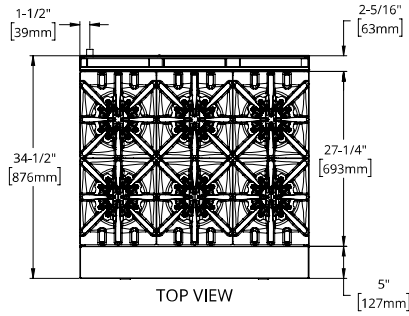

Gas input ratings shown for installations up to 2000 ft., (610m) above sea level. Please specify altitudes over 2000 ft.

This product is not approved for residential use.

Note: Installation clearance reductions are applicable only where local codes permit.

Model Number	Description	Total BTU/Hr Natural	Shipping Information	
			Lbs/Kg	Cu Ft
G36-6C	Six OB w/26" Convection Oven	236,000	430/195	40
G36-4G12C	12" G, Four OB w/26" Convection Oven	188,000	460/209	40
G36-2G24C	24" G, Two OB w/26" Convection Oven	140,000	495/225	40
G36-G36C	36" G w/26" Convection Oven	92,000	530/240	40

OB = Open Burner, G = Griddle

Note: Convection ovens with 120V, 60 Hz, 1-phase, 3.4 amps motors are supplied with 6'/1829mm cord and plug (NEMA 5-15P); 240V, 50/60 Hz, 1-phase motors are not supplied with cord and plug and must have direct connect.

Burner Ratings (BTU/Hr/kW)		
Burner	Natural	Propane
Open	33,000/9.67	30,000/8.79
Griddle/Hot Top	18,000/5.27	18,000/5.27
Convection Oven	38,000/11.13	32,000/9.38

Manifold Operating Pressure	
Natural	Propane
4.5" WC 11 mbar	10.0" WC 25 mbar

Model Type	Width	Depth	Height w/shelf	Oven Interior		
				Height	Depth	Width
Range Base	38-1/2" (900mm)	34-1/2" (974mm)	57" (1448mm)	13" (330mm)	22" (559mm)	26-1/4" (667mm)

Model Type	Combustible Wall Clearance		Entry Clearances	
	Sides	Rear	Crated	Uncrated
Range Base	14" (356mm)	6" (152mm)	37" (940mm)	36-1/2" (927mm)

Garland reserves the right to make changes to the design or specifications without prior notice.