

FRYERS

VULCAN**1ER50 SERIES
FREE STANDING ELECTRIC FRYERS****Model 1ER50D**

Shown with caster accessory

**SPECIFICATIONS**

Electric deep fat fryer, Vulcan Model No. (1ER50A) (1ER50D) (1ER50C). Temperature controls are adjustable from 200°F to 390°F and multiple fat melt cycles and high limit control. Stainless steel cabinet with four 6" adjustable legs. 16 gauge stainless steel fry tank holds 50 lbs. of frying compound. 1¼" full port ball type drain valve. 17kW low watt density ribbon style heating elements. Twin fry baskets. Power supply is 208 volt, 50/60 Hz, 3 phase.

Overall Dimensions:

15½" w x 34¾" d x 39⅞" h working height is 35¾".

NSF listed. CSA design certified.

Specify voltage when ordering.

- 1ER50A** Solid state analog knob control.
- 1ER50D** Solid state digital controls.
- 1ER50C** Programmable computer controls.

STANDARD FEATURES

- Stainless steel cabinet.
- Set of four 6" adjustable legs.
- 16 gauge stainless steel fry tank, 50 lb. capacity.
- Ten year limited fry tank warranty.
- 1¼" full port ball type drain valve.
- 17 kW low watt density ribbon style heating elements.
- Multiple fat melt modes.
- High limit control.
- Twin fry baskets with plastic coated handles.
- 208 volt, 3 phase.
- One year limited parts and labor warranty.

CONTROLS

- 1ER50A** Solid state knob control. Accurate temperature control 200°F to 390°F within +/- 2°. Multiple fat melt modes, fast recovery.
- 1ER50D** Solid state digital read temperature control. Accurate temperature control 200°F to 390°F within +/- 2°. Multiple fat melt modes, fast recovery and boil out mode and two countdown timers.
- 1ER50C** Computer control digital read temperature control. Accurate temperature control 200°F to 390°F within +/- 2°. Multiple fat melt modes, fast recovery and boil out mode. Ten programmable product keys and ten countdown timers. Secondary and advanced programming options.

OPTIONAL FEATURES (Factory Installed)

- Second year extended limited parts and labor warranty.

ACCESSORIES (Packaged & Sold Separately)

- Stainless Steel Tank Cover – doubles as a work surface top
- Set of four 6" adjustable casters (2 locking)
- Extra set of Twin Fry Baskets – 6½" w x 13¼" d x 6" h
- Large Single Fry Basket – 13" w x 13¼" d x 5½" h
- Frymate™ VX15S Dump Station
- Connecting Kit(s) – connect two fryers together (banking strip, brackets and hardware)
- 10" high stainless steel removable splash guard

VULCAN

a division of ITW Food Equipment Group LLC

P.O. Box 696 ■ Louisville, KY 40201 ■ Toll-free: 1-800-814-2028 ■ Local: 502-778-2791 ■ Quote & Order Fax: 1-800-444-0602



**1ER50 SERIES
FREE STANDING ELECTRIC FRYERS**

INSTALLATION INSTRUCTIONS

1. An adequate ventilation system is required for Commercial Cooking Equipment. Information may be obtained by writing to the National Fire Protection Association, Batterymarch Park, Quincy, MA 02269. When writing refer to NFPA No. 96.
2. All models require a 6" clearance at both sides and rear adjacent to combustible construction.
3. All models require a 16" (407 mm) minimum clearance to adjacent open top burner units.
4. This appliance is manufactured for commercial installation only and is not intended for home use.

SERVICE CONNECTIONS:

- Ⓔ 1. Each tank requires it's own separate power supply.
2. Power supply for basket lifts and/or filter motor is wired into the fryer's high voltage line terminal block, except for 480V which requires a separate 120V single phase electrical power connection NEMA 5-15P service for the basket lifts and filter motor, (not supplied with fryer).

NOTE: In line with its policy to continually improve its product, Vulcan reserves the right to change materials and specifications without notice.

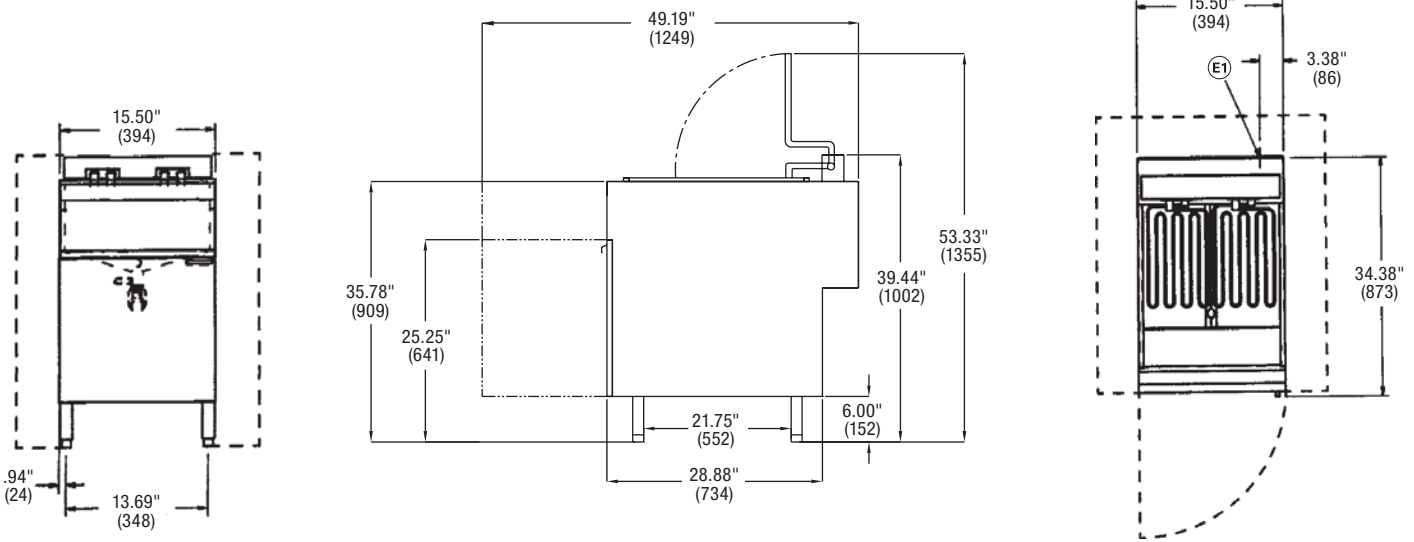

ELECTRICAL CHARACTERISTICS									
Model Number	Total kW Connection	3 PH Loading kW per Phase		Nominal Amps per Line Wire					
				3 Phase					
		208 volt	480 volt	208 volt			480 volt		
X-Y	X-Z	X	Y	Z	X	Y	Z		
1ER50	17	5.6	5.6	47	47	47	20	20	20

This appliance is manufactured for commercial use only and is not intended for home use.



a division of ITW Food Equipment Group LLC

P.O. Box 696 ■ Louisville, KY 40201 ■ Toll-free: 1-800-814-2028 ■ Local: 502-778-2791 ■ Quote & Order Fax: 1-800-444-0602