

Item #: 348DSF78 Project: \_\_\_\_\_

Qty: \_\_\_\_\_ Date: \_\_\_\_\_ Approval: \_\_\_\_\_

## Estella 85" Floor Reversible Dough Sheeter - 110V, 3/4 hp

Item #348DSF78



### Technical Data

Width	88 9/16 Inches
Depth	34 5/8 Inches
Height	46 7/16 Inches
Conveyor Length	85 Inches
Conveyor Width	19 3/4 Inches
Folded Width	29 1/2 Inches
Folded Depth	39 5/8 Inches
Folded Height	63 Inches
Amps	4.67 Amps
Hertz	60 Hertz

### Features

- Easily adjustable for any dough thickness between 1/32" and 1 3/8"
- Spacious 19 3/4" x 85" conveyor belt; 20 1/2" roller allows 11 lb. of dough at a time
- Reversible belt and durable stainless steel body for versatile, high-volume use
- Includes casters for mobility and folds up for compact storage
- Perfect for bakeries or pizzerias; 110V, 560W

### Certifications



5-15P



ETL Sanitation



ETL, US & Canada

## Technical Data

Phase	1 Phase
Voltage	110 Volts
Wattage	560 Watts
Belt Material	Polyurethane
Dough Capacity	11 lbs.
Horsepower	3/4 HP
Maximum Dough Thickness	1 3/8 Inches
Minimum Dough Thickness	1/32 Inch
Plug Type	NEMA 5-15P
Power Type	Electric
Style	Floor Model
Transmission Type	Belt-Driven
Type	Reversible Dough Sheeters

## Plan View

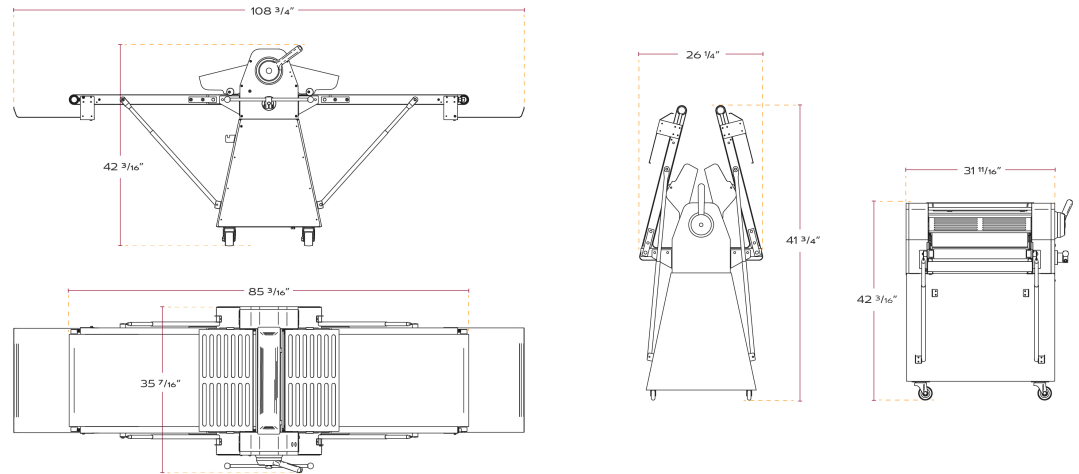

## Notes & Details

Save time and labor in your bakery or pizzeria by adding this Estella 85" reversible floor model dough sheeter to your preparation area. Designed to quickly roll out several pounds of dough per minute, this sheeter features a 20 1/2" roller and can produce dough thickness between 1/32" and 1 3/8". The roller is equipped to roll up to 11 lb. of dough at a time, perfect for high-volume operations. It utilizes a 19 3/4" wide conveyor to move dough through the machine, and the conveyor is reversible for quick rolling from either side of the unit to accommodate the flow of your operation.

This model is made of durable, corrosion-resistant stainless steel to withstand the rigors of commercial environments while remaining easy to clean at the end of the day. The supports on either end of the machine fold up for space-saving storage, and the entire unit is supported on four 2 1/2" casters, two of which lock to keep the unit in place when necessary. It also has several safety features to prevent worker injuries or damage to the motor, including safety guards and an emergency stop switch. A 110V electrical connection is required for operation.

**⚠ WARNING:** This product can expose you to chemicals including lead, which are known to the State of California to cause cancer, birth defects, or other reproductive harm. For more information, go to [www.p65warnings.ca.gov](http://www.p65warnings.ca.gov).