



DPW10
10 pans



JA5P2618 + DPW10

Mobile Warmers/Proofers

Doyon warmer/proofers provide uniform proofing and holding from top to bottom with their unique even flow system. These units have been designed for small and medium production of food products.

Can hold with ambient humidity or with optional humidity control (suffix S) on 1.9 kW unit instead of 1.4 kW

Versatility: Croissants, bagels, pastries, breads, rolls, food holding and much more.

DPW10

*“Superior quality product
at an affordable price !”*

Mobile Warmer / Proofers

Standard Features

- Glass doors
- Proofs from 90°F to 110°F (32°C to 43°C) with relative humidity up to 100 %
- Holding mode up to 180°F (82°C)
- Automatic water float system or manual water fill
- Powerful, efficient even airflow heating system, maintains the right combination of heat and humidity to proof or hold properly
- 304 Stainless steel inside and outside
- Heavy duty 3" (76 mm) non-marking swivel casters (2 with brakes)
- Water catch pan: keeps area dry, safer
- ETL & NSF listed
- One year parts and labor limited warranty

Optional

- 8 pans side racks (4 3/8" (111 mm) spacing)
- 9 pans side racks (3 7/8" (98 mm) spacing)
- 1.9 kW warmer + humidity
- Water softener system for installation

OVERALL DIMENSIONS

DPW10 38 1/4" W X 33 1/8" D X 45 1/4" H
(970 mm X 840 mm X 1150 mm)

INTERIOR DIMENSIONS

DPW10 26" W X 22" D X 37" H
(660 mm X 559 mm X 940 mm)

Shelf spacing 3 1/2" (89 mm)

ELECTRICAL SYSTEM

DPW10 (1400 W)

120V 1 PH 1.4 kW 11.7A 50/60 Hz NEMA 5-15P

220V 1 PH 1.4 kW 6.4A 50/60 Hz NEMA 6-15P

DPW10S (1900 W)

120V 1 PH 1.9 kW 15.8A 50/60 Hz NEMA 5-20P

220V 1 PH 1.9 kW 8.6A 50/60 Hz NEMA 6-15P

CAPACITY

10 pans

FINISH

304 Stainless steel

SHIPPING INFORMATION

350 lbs (159 kg) approximately

Water inlet and electrical service connection located at the back of the unit.

Specifications and design subject to change without notice.

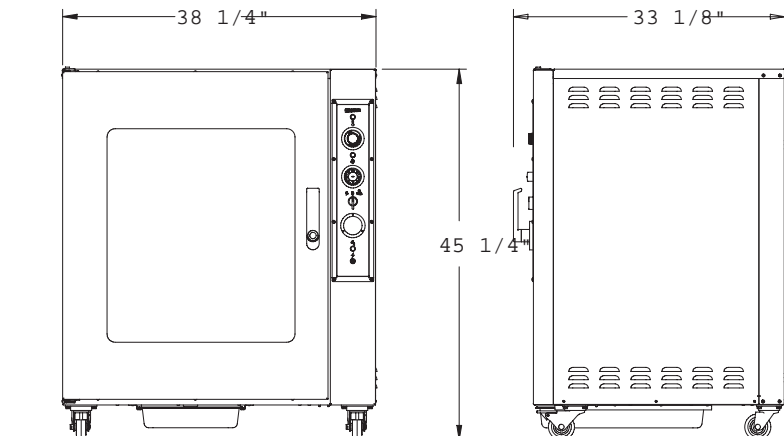

1255, rue Principale
Linière, Beauce, Québec, Canada G0M 1J0

Telephone : (418) 685-3431 Fax: (418) 685-3948
Canada : (800) 463-1636 U.S.: (800) 463-4273
E-Mail : doyon@doyon.qc.ca Internet: <http://www.doyon.qc.ca>



Your local distributor:

