

351WOKR13L

Cooking Performance Group WOKR13L Liquid Propane Wok Range with 13" Ring - 95,000 BTU



Item #: 351WOKR13L Qty: _____

Project: _____

Approval: _____ Date: _____

Features

- Includes a 13" ring to support your large woks
- Equipped with an 18 tip duck jet burner
- Drip tray for easy cleanup
- Stainless steel front, sides, adjustable legs, and base
- Requires a liquid propane connection; adjustable valve provides 95,000 BTU

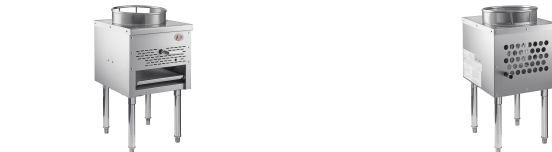

Technical Data

Width	17 1/2 Inches
Depth	24 Inches
Height	34 Inches
Ring Diameter	13 Inches
Burner BTU	95000 BTU
Features	Field-Convertible (Gas) Massachusetts Accepted Plumbing Product
Gas Connection Size	3/4 Inches
Installation Type	Freestanding
Number of Burners	1 Burner

Certifications



ETL Sanitation



ETL, US & Canada



3/4" Gas Connection



Field Convertible (Gas)

351WOKR13L

Cooking Performance Group WOKR13L Liquid Propane Wok Range with 13" Ring - 95,000 BTU



Technical Data

Power Type	Liquid Propane
Total BTU	95000 BTU
Type	Wok Ranges

Plan View

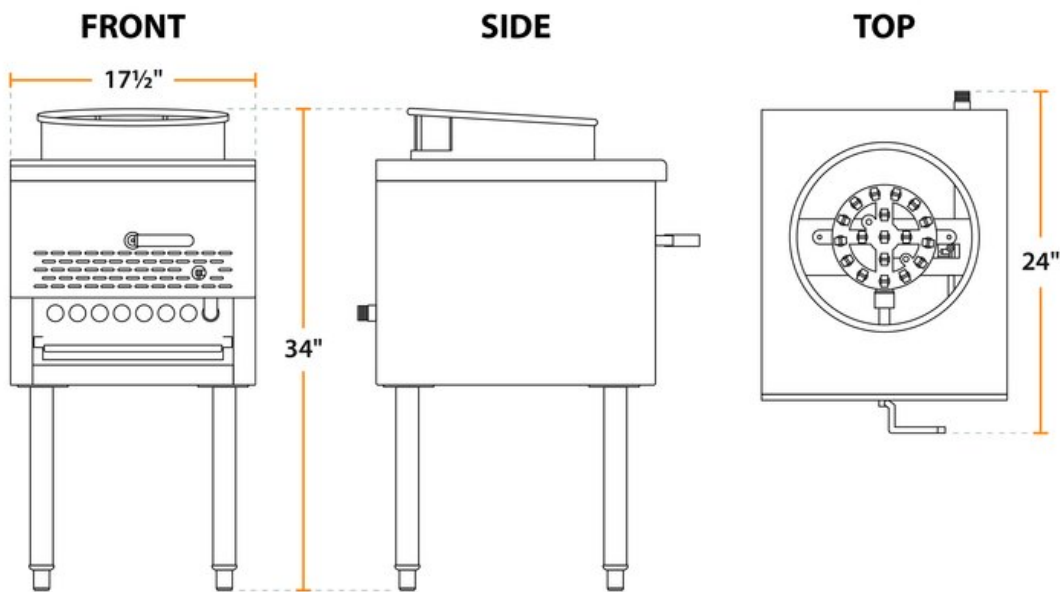

351WOKR13L

Cooking Performance Group WOKR13L Liquid Propane Wok Range with 13" Ring - 95,000 BTU



Notes & Details

This Cooking Performance Group WOKR13L 13" liquid propane wok range allows you to quickly and easily prepare your most delicious stir fries, sauteed dishes, and noodles while taking up minimal space in your kitchen! A perfect addition to your buffet, Japanese steakhouse, Asian restaurant, or catering company, this wok range boasts a powerful 18 tip duck jet burner that delivers up to 95,000 BTUs of cooking power.

This unit's stainless steel wok attachment measures 13" in diameter to accommodate your largest woks. Its rolled front makes it easy to load, while its gradual slope design helps reduce food spillover during cooking. Boasting a stainless steel front, bottom, and cabinet, this unit provides long-lasting durability and is easy to clean after a busy dinner service. Its convenient removable drip pan collects grease to ensure your cooking area stays cleaner during use.

The unit sits on tall legs with adjustable feet to ensure level installation on uneven surfaces. It requires a liquid propane connection for operation, but it's field convertible to operate on natural gas.

⚠ WARNING: This product can expose you to chemicals including lead, which are known to the State of California to cause cancer and birth defects or other reproductive harm. For more information, go to www.p65warnings.ca.gov.