

351S60G36N

Cooking Performance Group S60-G36-N Natural Gas 4 Burner 60" Range with 36" Griddle and 2 Standard Ovens - 240,000 BTU



Item #: 351S60G36N Qty: _____

Project: _____

Approval: _____ Date: _____

Features

- (4) 30,000 BTU open top burners with cast iron lift-off grates for easy cleaning
- 36", 3/4" thick manual steel griddle with (3) 20,000 BTU burners
- Rugged stainless steel front and aluminum sides; porcelainized oven bottom
- 9 1/2" deep back shelf and 4 1/2" plate rail for added storage and safety
- Requires a natural gas connection



Certifications



ETL Sanitation



ETL, US & Canada



3/4" Gas Connection

Technical Data

Width	60 Inches
Depth	32 5/8 Inches
Height	60 Inches
Griddle Width	36 Inches
Nominal Width	60 Inches
Oven Interior Width	26 7/8 Inches
Oven Interior Depth	25 7/8 Inches
Oven Interior Height	13 7/8 Inches
Burner BTU	30000 BTU
Features	Massachusetts Accepted Plumbing Product

351S60G36N

Cooking Performance Group S60-G36-N Natural Gas 4 Burner 60" Range with 36" Griddle and 2 Standard Ovens - 240,000 BTU



Technical Data

Gas Connection Size	3/4 Inches
Griddle BTU	60000
Installation Type	Freestanding
Number of Burners	4 Burners
Number of Ovens	2 Ovens
Number of Racks	4 Racks
Oven BTU	30000 BTU
Plate Thickness	3/4 Inch
Power Type	Natural Gas
Range Base Style	Standard Oven
Style	Standard
Temperature Range	250 - 550 Degrees F
Top Configuration	Burners with Right Griddle
Total BTU	240000 BTU

Plan View

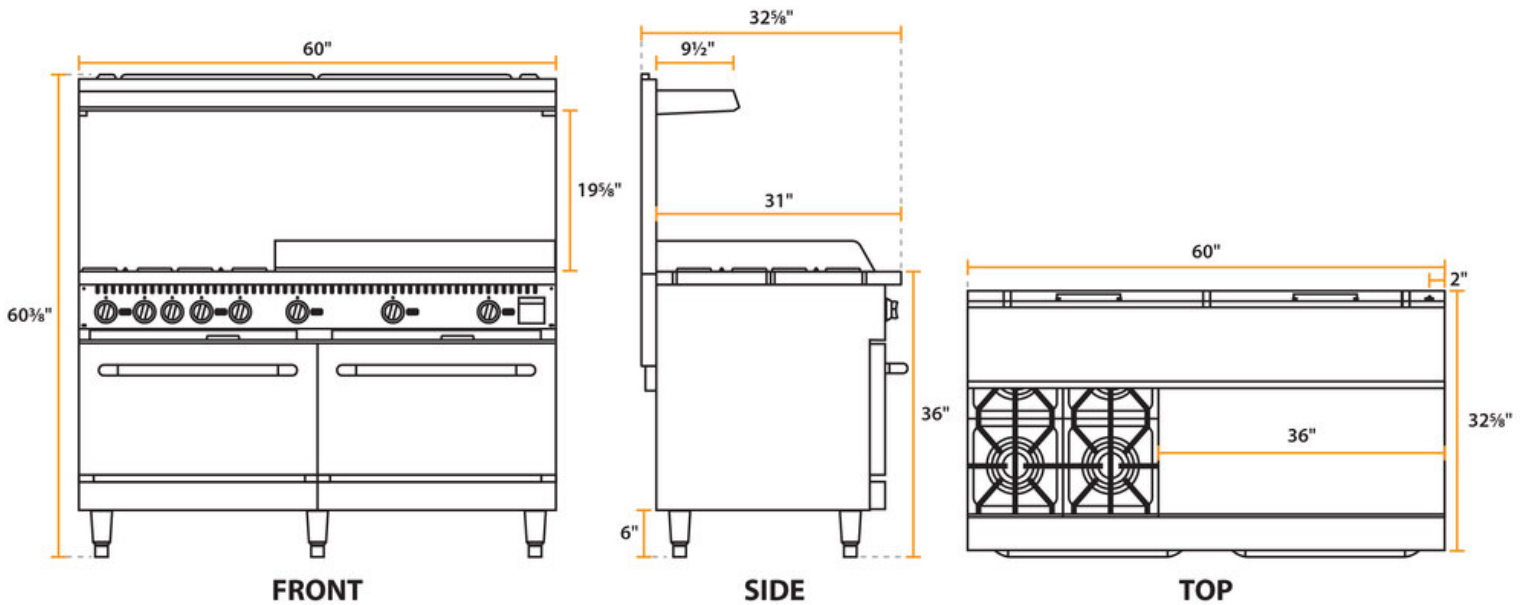

351S60G36N

Cooking Performance Group S60-G36-N Natural Gas 4 Burner 60" Range with 36" Griddle and 2 Standard Ovens - 240,000 BTU



Notes & Details

Boost your kitchen's efficiency, reliability, and overall performance with this Cooking Performance Group gas range! This natural gas range boasts (4) 30,000 BTU open top burners to deliver the impressive cooking performance you demand. The independently-controlled burners mean you can simultaneously execute a wide variety of tasks while their 12" x 12" heavy-duty cast iron grates support your sauce pans, fry pans, and other cookware. These rugged grates allow you to confidently boil, sauté, and simmer as needed while effortlessly sliding even the heaviest stock pots from one burner to another. Backed by (3) 20,000 BTU burners, this range's 36" steel griddle gives you plenty of space to grill hamburgers, chicken, fish, or even bacon and eggs! A 4 1/2" plate rail gives you a bit of extra room to work with and combines with a 9 1/2" deep back shelf that holds go-to seasonings and supplies to maximize your cooktop efficiency.

Two 30,000 BTU standard ovens make this unit even more versatile by giving you a convenient way to warm your delicious foods or even do a bit of baking for your dessert menu! The ovens' temperature can be adjusted from 250-550 degrees Fahrenheit to accommodate virtually any recipe. With 2 chrome plated racks that can be used in 4 different positions within each cavity, you can easily arrange the ovens to best complement your specific needs.

This 60" range features a rugged stainless steel front and durable aluminum sides that are not only designed to provide you with years of trouble-free performance, but are also extremely simple to clean! The cast iron grates lift off for a simple, thorough cleansing while the deep pull-out crumb tray further expedites end-of-day cleanup. And, thanks to the porcelainized bottom, maintaining a spotless oven is easier than ever. 6" adjustable stainless steel legs ensure that your unit is level and allows you to easily clean underneath for a safe and sanitary kitchen. A natural gas connection is required for operation.

⚠ WARNING: This product can expose you to chemicals including chromium (hexavalent compounds), which are known to the State of California to cause cancer and birth defects or other reproductive harm. For more information, go to www.p65warnings.ca.gov.