

351S36SBNWK

Cooking Performance Group S-36-SB-N 36" Natural Gas Infrared Salamander Broiler with Wall Mounting Bracket - 36,000 BTU



Item #: 351S36SBNWK Qty: _____

Project: _____

Approval: _____ Date: _____

Features

- Natural gas, 36,000 BTU
- Includes wall mounting bracket
- Durable stainless steel front and sides
- Gas-fired infrared burner efficiently browns casseroles or toasts sandwiches
- Lever controlled rack height to adjust product for the perfect heat application



Certifications



ETL, US & Canada



ETL Sanitation



1/2" Gas Connection

Technical Data

Width	34 7/8 Inches
Depth	20 3/4 Inches
Height	23 1/4 Inches
Interior Width	27 Inches
Interior Depth	18 1/5 Inches
Interior Height	14 Inches
Gas Connection Size	1/2 Inches
Installation Type	Wall Mounted
Number of Shelves	1 Shelf
Power Type	Natural Gas

3515365BNWK

Cooking Performance Group S-36-SB-N 36" Natural Gas Infrared Salamander Broiler with Wall Mounting Bracket - 36,000 BTU



Technical Data

Temperature Range	80 - 400 Degrees F
Total BTU	36000 BTU
Type	Salamanders

Plan View

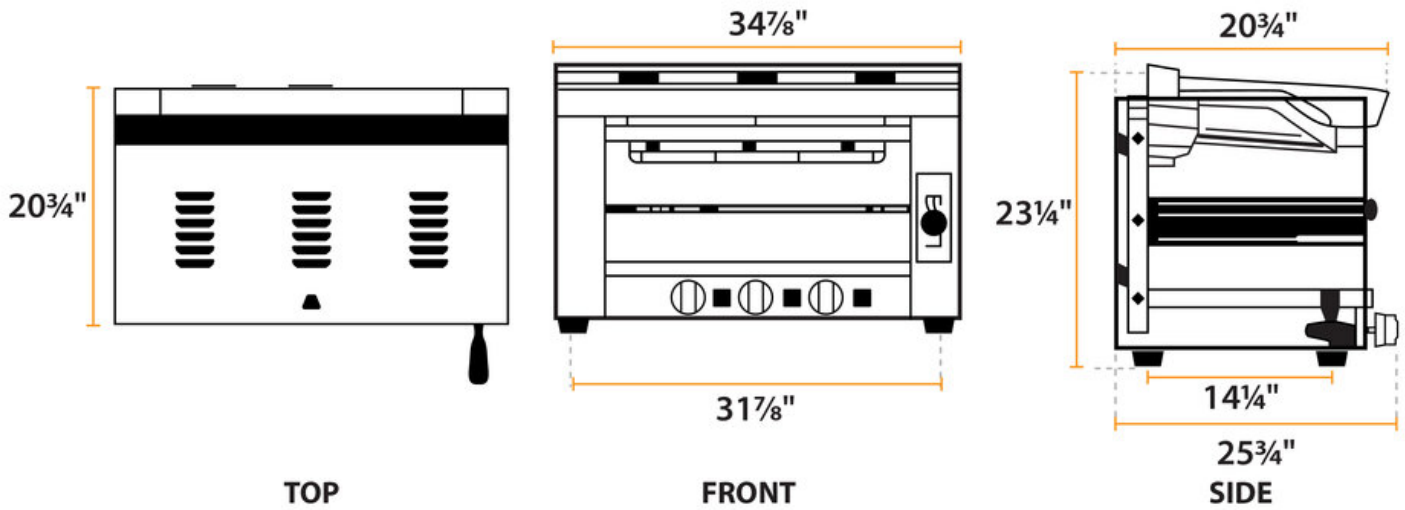

3515365BNWK

Cooking Performance Group S-36-SB-N 36" Natural Gas Infrared Salamander Broiler with Wall Mounting Bracket - 36,000 BTU



Notes & Details

An excellent addition to your kitchen's equipment lineup, this Cooking Performance Group S-36-SB-N natural gas 36" salamander broiler allows you to quickly and easily melt cheese, brown the top of casseroles, toast sandwiches, or even finish steaks and other meats! It is equipped with a gas-fired 36,000 BTU infrared burner with adjustable gas valves and a standing pilot for instant ignition. With a temperature range of 80-400 degrees Fahrenheit, this unit can handle a variety of cooking tasks, improving the efficiency of your kitchen by offering a versatile piece of equipment in a compact size.

This broiler features a sleek stainless steel front and sides, making it both durable and easy to clean! A full width, large capacity broiler pan can also be removed for convenient cleaning. For easy setup, this model includes a wall mounting bracket and hardware so that you do not have to take up valuable floor space with an equipment stand.

A model of versatility, the Cooking Performance Group S-36-SB-N salamander broiler has a spring-balanced, adjustable tension assembly that raises and lowers with positive multi-position locking, and also rolls out for easy loading, unloading, and cleaning. A stainless steel crumb tray easily slides out of the unit to remove dropped food. A natural gas connection is required for operation.

⚠ WARNING: This product can expose you to chemicals including lead, which are known to the State of California to cause cancer and birth defects or other reproductive harm. For more information, go to www.p65warnings.ca.gov.