

351GTCPG15NL

# Cooking Performance Group GT-CPG-15-NL 15" Gas Countertop Griddle with Flame Failure Protection and Thermostatic Controls - 30,000 BTU



Item #: 351GTCPG15NL Qty: \_\_\_\_\_

Project: \_\_\_\_\_

Approval: \_\_\_\_\_ Date: \_\_\_\_\_

## Features

- 30,000 BTU burner
- Features an adjustable thermostatic control
- Standing pilot for instant ignition
- Heavy-duty, adjustable feet provide stability
- Field convertible to liquid propane; includes orifice for connection

## Technical Data

Width	15 Inches
Depth	29 5/16 Inches
Height	16 5/16 Inches
Cooking Surface Width	15 Inches
Cooking Surface Depth	20 Inches
Backsplash	With Backsplash
Burner BTU	30000 BTU
Burner Style	U-Shaped
Control Type	Thermostatic
Cooking Surface Material	Polished Steel



## Certifications



ETL Sanitation



3/4" Gas Connection



Field Convertible  
(Gas)



ETL, US & Canada

# Cooking Performance Group GT-CPG-15-NL 15" Gas Countertop Griddle with Flame Failure Protection and Thermostatic Controls - 30,000 BTU



## Technical Data

Features	Massachusetts Accepted Plumbing Product
Installation Type	Countertop
Number of Burners	1 Burner
Number of Controls	1 Controls
Plate Thickness	3/4 Inch
Power Type	Natural Gas
Temperature Range	200 - 575 Degrees F
Temperature Settings	Adjustable
Total BTU	30000 BTU
Type	Griddles
Usage	Medium Duty

## Plan View

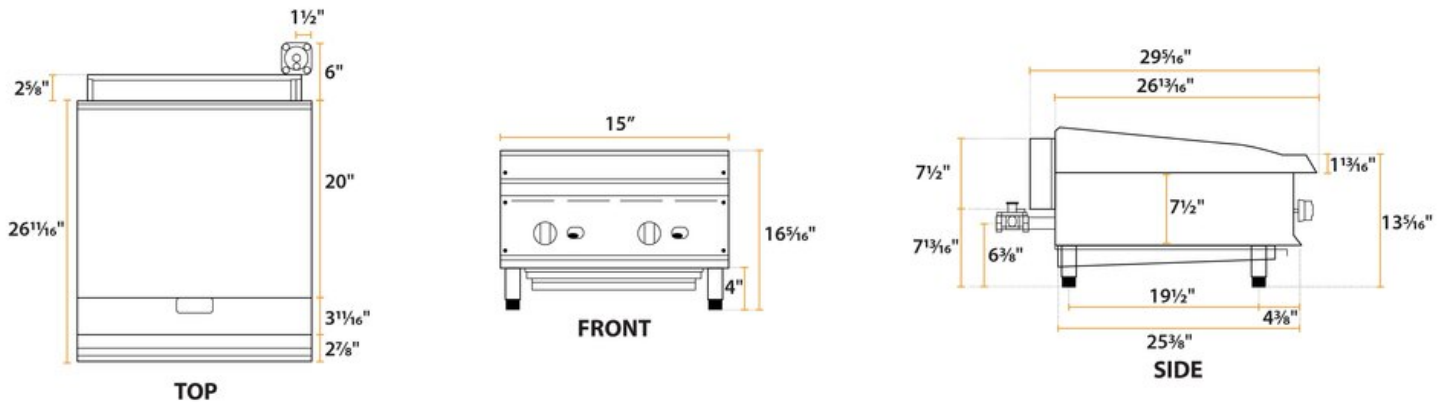

351GTCPG15NL

## Cooking Performance Group GT-CPG-15-NL 15" Gas Countertop Griddle with Flame Failure Protection and Thermostatic Controls - 30,000 BTU



### Notes & Details

This Cooking Performance Group GT-CPG-15-NL 15" countertop griddle features an energy saving thermostat that is adjustable from 200 to 575 degrees Fahrenheit for precise temperature control, making it an excellent choice for delicate breakfast foods like eggs and hotcakes, as well as your lunch menu of chicken, hamburgers, and other meats! It boasts a powerful 30,000 BTU stainless steel U-shaped burner with a standing pilot for instant ignition that works in perfect harmony with the thermostat to maintain your selected griddle temperature during peak cooking periods. Its flame failure protection system guarantees safety and peace of mind. The 3/4" thick, 15" wide polished steel cooking surface features an impressive 20" depth that is sure to deliver all of the workspace needed.

The Cooking Performance Group GT-CPG-15-NL countertop griddle is made of stainless steel that is both durable and extremely easy to clean, includes back and side splashes to protect your walls and countertops, and even has a full width waste tray to provide you with a complete package of excellent performance and worry-free maintenance! It has a 3/4" rear gas connection and ships ready to connect to a natural gas supply, but includes a liquid propane orifice kit for simple field conversion.

**⚠ WARNING:** This product can expose you to chemicals including lead, which are known to the State of California to cause cancer and birth defects or other reproductive harm. For more information, go to [www.p65warnings.ca.gov](http://www.p65warnings.ca.gov).