



Item #: 382CDPW2 Project: \_\_\_\_\_

Qty: \_\_\_\_\_ Date: \_\_\_\_\_ Approval: \_\_\_\_\_

# Carnival King 3 Qt. Double Cone Dip Warmer - 120V, 200W

Item #382CDPW2



## Technical Data

Width	14 5/8 Inches
Depth	9 1/4 Inches
Height	8 1/3 Inches
Phase	1 Phase
Voltage	120 Volts
Wattage	200 Watts
Application	All-Purpose
Capacity	6 qt.
Color	Silver
Cover Type	Hinged



## Features

- Includes (2) 3 qt. wells
- Perfect for dipping ice cream cones, fruit, pretzels, and other treats for added flavor
- Infinite control adjusts from low to high (max 165F)
- Stainless steel with a stay-open hinged lid and top flange to hold container in place
- 120V, 200W

## Certifications



ETL Sanitation



ETL, US & Canada



5-15P

## Technical Data

<b>Dispenser Type</b>	Cone Dip Warmer
<b>Installation Type</b>	Countertop
<b>Material</b>	Stainless Steel
<b>Maximum Temperature</b>	165 Degrees F
<b>Number of Compartments</b>	2 Compartments
<b>Plug Type</b>	NEMA 5-15P
<b>Power Type</b>	Electric
<b>Style</b>	Warmer
<b>Temperature Control</b>	Infinite
<b>Temperature Settings</b>	Adjustable
<b>Type</b>	Warmers

## Plan View

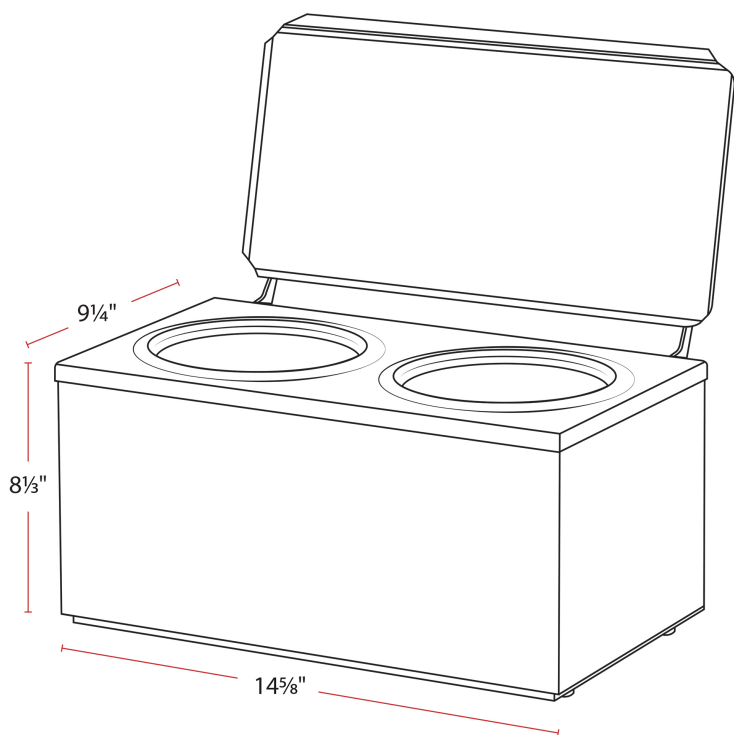

## Notes & Details

Enhance your dessert menu and increase your margins by dipping ice cream cones, fruit, and other treats with this Carnival King 3 qt. double cone dip warmer. This unit holds two 3 qt. jars (sold separately) or #10 cans of sauce for easy dipping. Just remove the top panel, place the container inside, and replace the top. A flange holds the container in place and helps prevent product from dropping into the warmer. For easy access, lift the hinged lid and prop it open. It will stay open for mess-free dipping and then close to prevent contamination in between uses.

To warm caramel, chocolate sauce, or fruity flavoring, an adjustable infinite knob controls the heating element. The infinite control ranges between ambient temperatures and 165 degrees Fahrenheit so you can warm sauces at the proper temperatures. Perfect for a variety of venues, this cone dip warmer helps expand your dessert menu and offer limited time flavor and toppings! Rotate the sauce of the day, or highlight a flavor as part of a seasonal promotion in your ice cream parlor, restaurant back-of-house, food truck, or concession stand. The warmer includes (6) vinyl flavor decal stickers. Built for convenience, the top and bottom are removable for easy cleaning. A 120V, 200W electrical connection is required for operation.

**⚠ WARNING:** This product can expose you to chemicals including lead, which are known to the State of California to cause cancer, birth defects, or other reproductive harm. For more information, go to [www.p65warnings.ca.gov](http://www.p65warnings.ca.gov).