

BACKYARD PRO

Backyard Pro BPF80 70 - 80 lb. Double Tank Portable Outdoor Fryer - 180,000 BTU

#554BPF80



Technical Data

Width	63 1/4 Inches
Depth	31 1/4 Inches
Height	49 1/2 Inches
Fry Pot Width	14 Inches
Fry Pot Depth	13 3/4 Inches
Fry Pot Height	12 1/4 Inches
Burner BTU	180000 BTU
Casters	With Casters
Control Type	Thermostatic
Fryer Usage	High Production

Features

- Includes 4 fryer baskets, 2 frypot covers, and regulator hose for propane tank
- Convenient stainless steel side shelf and hook for additional storage
- Uses standard 30 lb. propane tank (sold separately)
- Integrated bar for hanging fry baskets
- Mobile design is ideal for caterers, company parties, and special events

Certifications



ETL Sanitation



Portable LP Tank Connection



ETL, US & Canada

Technical Data

Features	Add-On Shelf Frypot Cover
Material	Stainless Steel
Number of Fry Baskets	4 Fry Baskets
Number of Fry Pots	2 Fry Pots
Oil Capacity	70 - 80 lb.
Power Type	Liquid Propane
Temperature Range	200 - 400 Degrees F
Total BTU	180000 BTU
Type	Fryers

Plan View

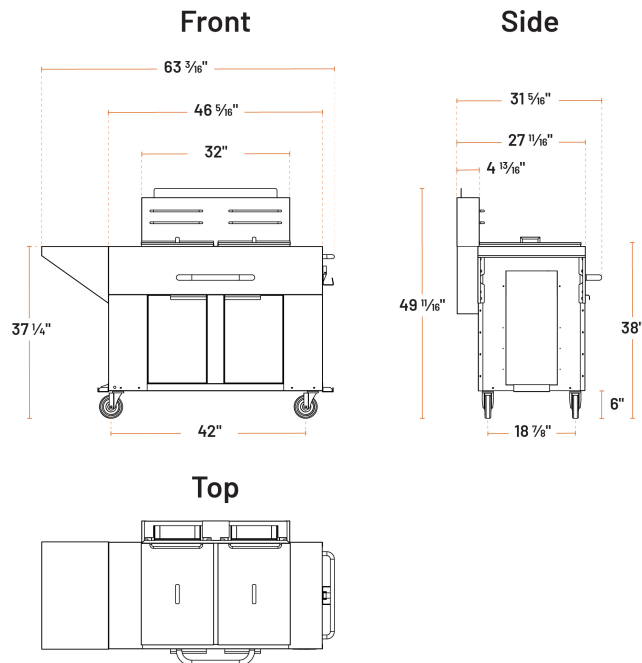

Notes & Details

Introduce high-volume frying to your poolside or concession stands with this Backyard Pro BPF80 70 - 80 lb. double tank portable outdoor fryer. Holding up to four fry baskets, the 180,000 BTUs of power enable you to cook up 130 lb. of frozen french fries per hour. The frying wells can hold between 70 and 80 lb. of oil (35-40 lb. each). This outdoor fryer uses a standard 30 lb. propane tank (sold separately) for quick heat up times and fast recovery, while the thermostatic control lets you adjust the temperatures between 200 and 400 degrees Fahrenheit.

Built on 4 casters, 2 of which are locking, this fryer can maneuver around easily, making it the perfect choice for catering, party rentals, or even moving it around a resort venue! A handle on the front of the unit will offer more control over steering and it includes frypot covers. The exterior is made with 304 stainless steel which is both durable and rust-resistant. The interior is made with a combination of galvanized steel and 304 stainless steel to ensure this fryer can endure the rigorous demands of daily use.

Store service plates, ready to cook product, or condiments with the convenient stainless steel shelf mounted on the side of the unit. Underneath the shelf is a small hook for hanging tools nearby. Above the frying vat is a thin bar, which is designed to hold idle baskets for drainage. The elevated wall around the well adds an extra layer of safety for the user when frying. This outdoor, portable fryer will ensure you can serve freshly fried food anywhere!

 **WARNING:** This product can expose you to chemicals including lead, which are known to the State of California to cause cancer, birth defects, or other reproductive harm. For more information, go to www.p65warnings.ca.gov.